

Distributed By:  
**Custom Equipment Company**  
 866-333-0728 919-847-5765 fax  
 sales@custommhs.com  
 www.custommhs.com

# WireCrafters

## Installation Instructions

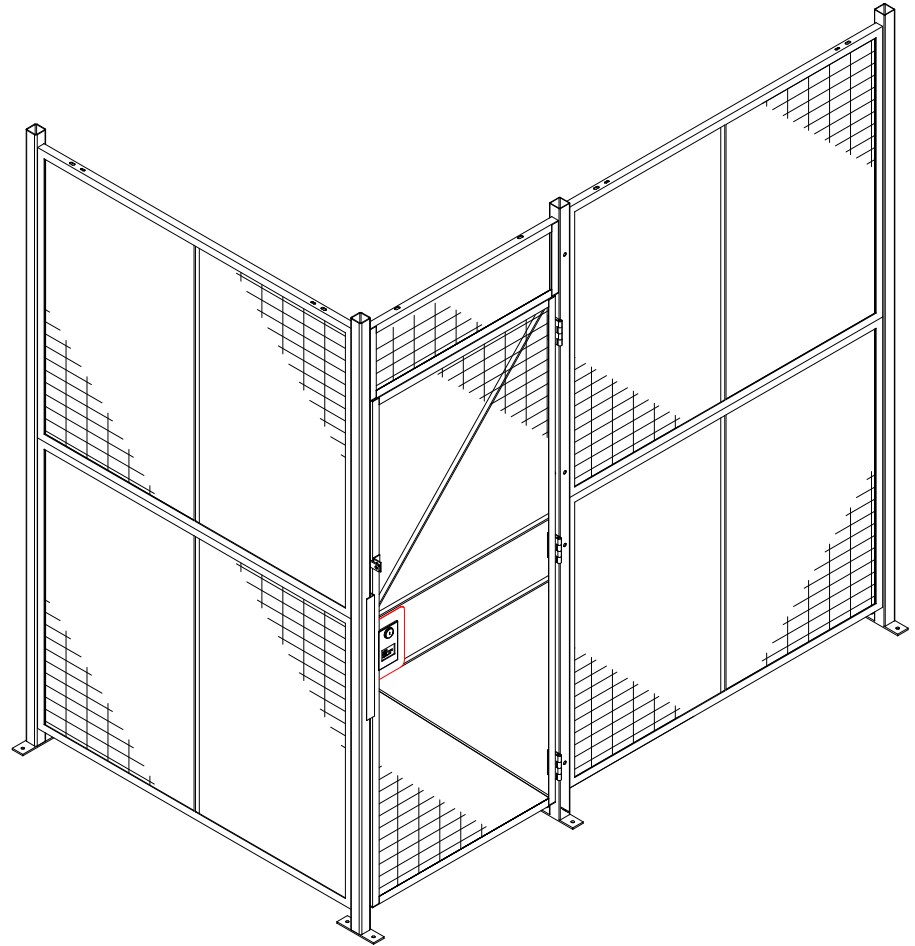

### INCLUDED IN THIS MANUAL

|                           |       |                                  |    |
|---------------------------|-------|----------------------------------|----|
| General Information       | 2     | Slide Door Receiver              | 17 |
| Panels & Posts            | 3     | Tunnel Door                      | 18 |
| Adjustable panels         | 4     | Basic Ceiling                    | 19 |
| TES-4 & JSPE Detail       | 5     | 2" x 2" Horizontal Ceiling Tube  | 20 |
| Hinge Door Hardware       | 6     | 2" x 4" Horizontal Ceiling Tube  | 21 |
| Hinge Door Inside Swing   | 7     | 2" x 6" Horizontal Ceiling Tube  | 22 |
| Hinge Door Outside Swing  | 8     | Ceiling Tube Masonry Connections | 23 |
| Dutch Door                | 9     | Physical Barrier                 | 24 |
| Double Hinge Door         | 10    | Barrier Hinge Door Outside Swing | 25 |
| Slide Door Hardware       | 11    | Barrier Hinge Door Inside Swing  | 26 |
| Slide Door Outside        | 12-13 | Rack Back®                       | 27 |
| Slide Door Inside         | 14-15 | Rack Back® Hinge Door            | 28 |
| Slide Door Panel Assembly | 16    | Component Location Work Sheet    | 29 |

We're Here To Help  
 1-800-626-1816  
 Mon-Fri 8am-5pm ET

**Reference: Custom Equipment Company**

The following General Installation Instructions should be used as a guide for installing WireCrafters Style 840 Partitions. Because of the varying job site conditions, and infinite layout possibilities, there is no “recommended” way to install the product. Good common sense and proper safety precautions must be used during installation. The product may be unstable during installation; proper temporary bracing should be used until all hardware is tightened and the product is properly anchored to the floor. Permanent field bracing may be installed at installer’s/owner’s discretion. Install problems arising from job site conditions should be referred to a professional installer. Refer product assembly questions to WireCrafters.

## TOOLS RECOMMENDED

|                     |  |  |
|---------------------|--|--|
| Chalk line & marker | Drill with adjustable clutch and 3/8” nut driver | (2) Step ladders if installing ceiling   |
| Tape Measure        | Hammer Drill with 3/8” masonry bit               | (2) C clamps or Vise-Grip® type clamps   |
| Level               | (2) 9/16” open end wrenches and/or               | #1 & #2 Phillips Screw Driver            |
| Hacksaw             | (2) 9/16” deep socket ratchets                   | 1/2” deep socket or 1/2” open end wrench |

## SELF DRILLING SCREW INSTALLATION RECOMMENDATIONS

When installing self drilling screws use a standard variable speed screw gun equipped with an adjustable clutch or depth locating nose piece. Take care not to over tighten or strip, set drill accordingly. **DO NOT USE IMPACT TYPE GUN WHEN INSTALLING SELF DRILLING SCREWS.** Securely clamp component parts in place before attaching with self drilling screws.

## INSTALLER TIPS

1. Installation is best accomplished with a two or three person crew.
2. Before starting, review all installation instructions pertinent to your layout (i.e. panels, doors, etc.)
3. “Face Side” of the partition is the outside, where nuts and bolts will NOT be visible or accessible. “Inside” of the partition has one leg of the panel frame pointing in. Assembly hardware will be on the inside of most layouts.
4. Panels install horizontally between posts, 2” mesh opening should be parallel with floor.
5. Identify all panels by part number. If possible stage parts where they will be installed.
6. Special size panels have metal tags on the mesh and are referenced on drawing.
7. Make sure all posts are installed plumb (vertically perpendicular to floor). Shims (not provided) may be necessary.
8. Use a 3-1/4” spacer block (not provided) to support far end of panel during setup.
9. Begin installation process at a building wall, end or corner of layout.
10. Gauge hinge door opening by width of transom panel.
11. Gauge slide door opening by door width (e.g. 48” between posts for 4’ wide slide door). When necessary, slide door openings may be narrowed to adjust length of adjacent run.
12. Standard hinge, double hinge, and slide doors are universal and may be installed inside or outside swing, left or right hand. Dutch and special doors are not universal and must be installed as shown out on drawing.
13. Installer should cut off any bolts or hardware protruding into aisle ways or around door openings.
14. Installer should touch up all nicks, marks, and scratches with touch up paint provided.

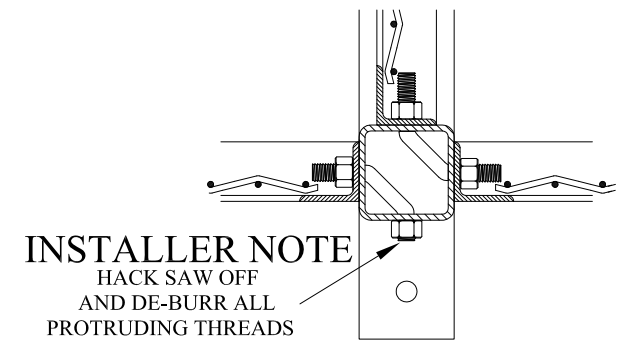
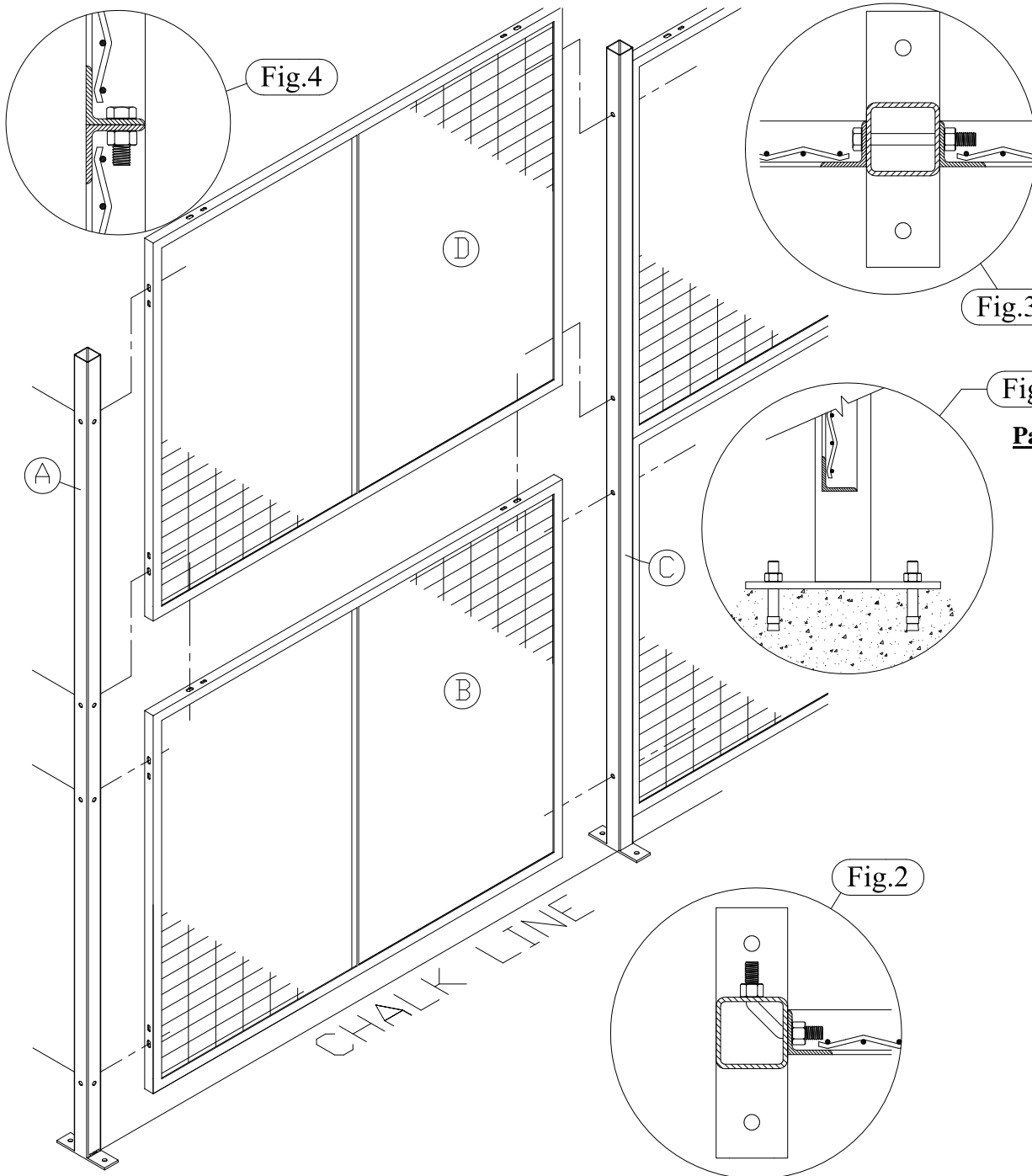

**INSTALLER NOTE**  
HACK SAW OFF  
AND DE-BURR ALL  
PROTRUDING THREADS

TYPICAL TEE-POST CONNECTION

**Panels and Posts Installation**

1. Use a chalk line to outline the partition layout on the floor.
  - a. Out to out dimensions shown on drawing are to face side of posts.
  - b. Post base plates project 2-1/2" beyond outline of partition.
2. Lag end post (A) to floor per Fig. 1 using two anchors provided.
  - a. If end of partition mounts directly to building wall, support panel with 3-1/4" spacer block, and mount panel to wall with appropriate wall mount kit.
3. Mount bottom panel (B) to post (A)
  - a. Per Fig. 2 for corner post using two 3/8" corner bolts, or
  - b. Per Fig. 3 for run post using two 3/8" x 3" straight bolts, or
  - c. If mounting directly to building wall, skip this step.
  - d. **Note: Panels install horizontally; 2" mesh opening parallel with floor.**
4. Attach opposite end of panel (B) to second post (C)
  - a. per Fig.2 for corner post, or
  - b. Per Fig.3 for run post.
5. Lag post to floor using two anchors provided
6. Install top panel (D) between posts and bolt to lower panel (B) per Fig 4 using 3/8" x 1" nuts and bolts.

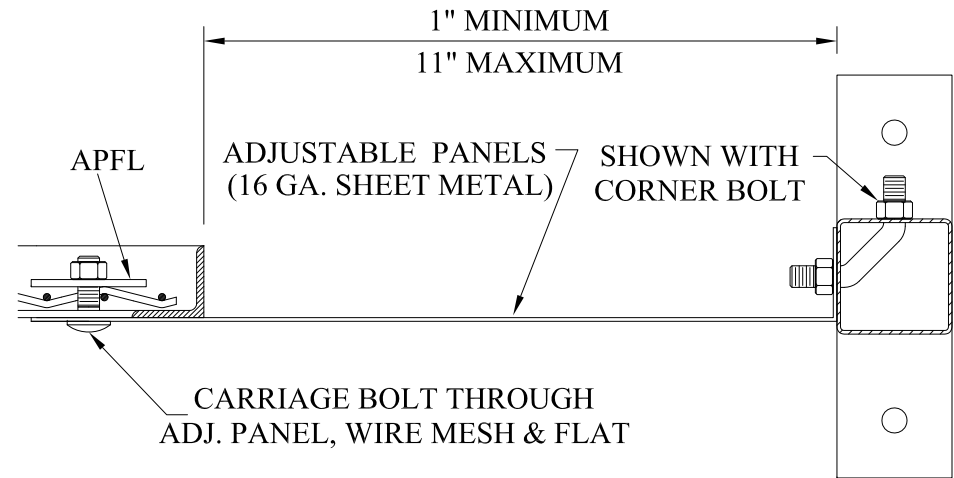
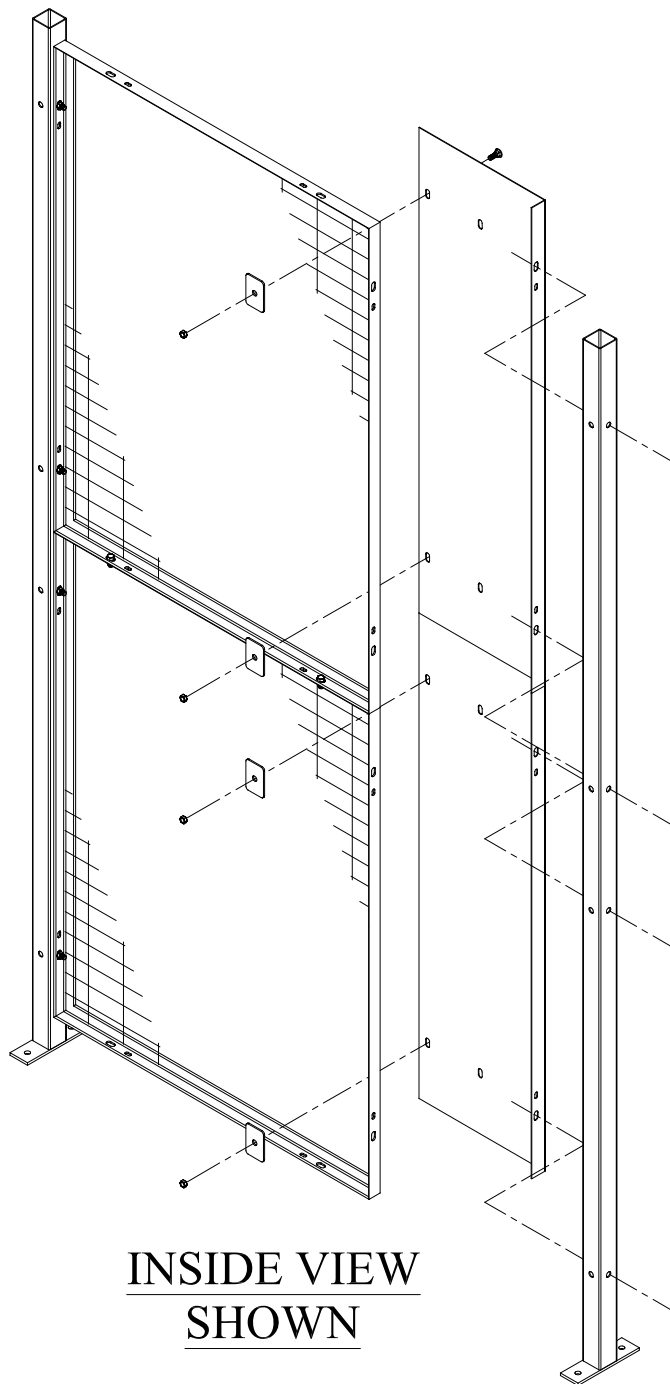
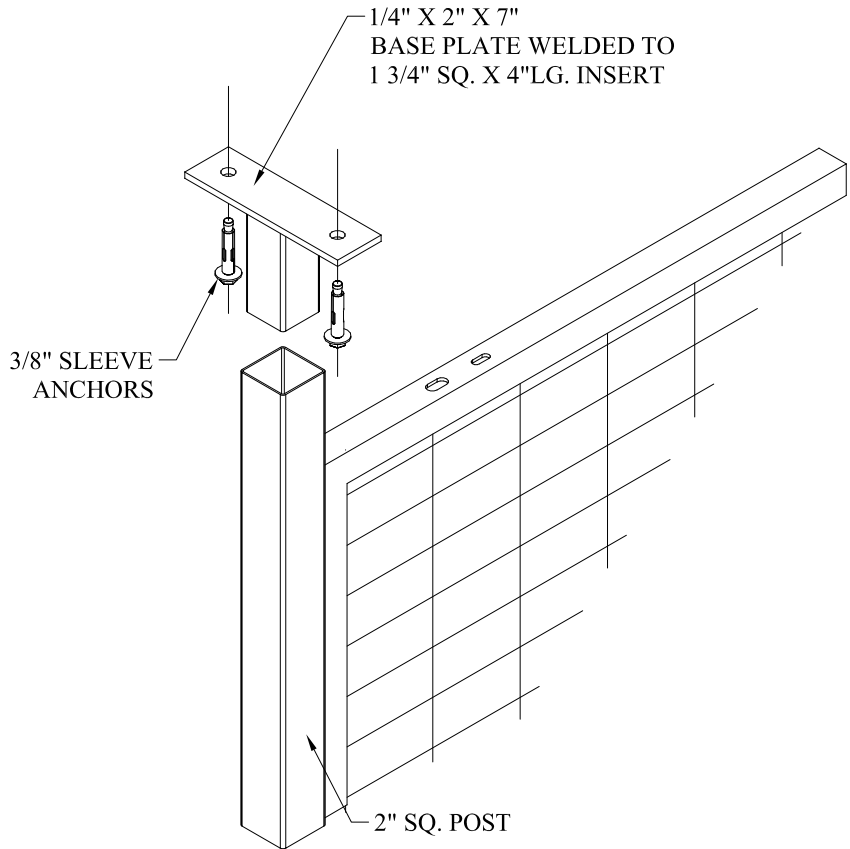

Fig.1

### Adjustable Panel (AP) Installation

Used to fill gaps of 1" to 11" in partition runs.

1. Place 3-1/4" spacer block under non-supported end of partition run.
2. Fit the AP panel in the gap between the end post (or building wall) and wire mesh panel.
  - a. The flat edge of the AP panel should overlap the face side of the wire mesh panel, and the edge with the 90 degree bend should be against the post or wall.
3. Bolt the angle edge of the AP to the post using two 3/8" x 3" straight bolts, or two 3/8" corner bolts (use wall mount kit if mounting to building wall).
4. Attach flat side of one AP to face side of bottom panel on partition wall by placing two 3/8" x 1" carriage bolts through the AP, mesh and adjustable flats (part APFL); secure with 3/8" nuts per Fig.1.
5. Bolt the angle edge of the AP to the post using two 3/8" x 3" straight bolts, or two 3/8" corner bolts (use wall mount kit if mounting to building wall).
6. Repeat for upper panel.
7. Remove and discard spacer block.



## DETAIL TES-4

Accessory item used to anchor  
partition wall to overhead structure.

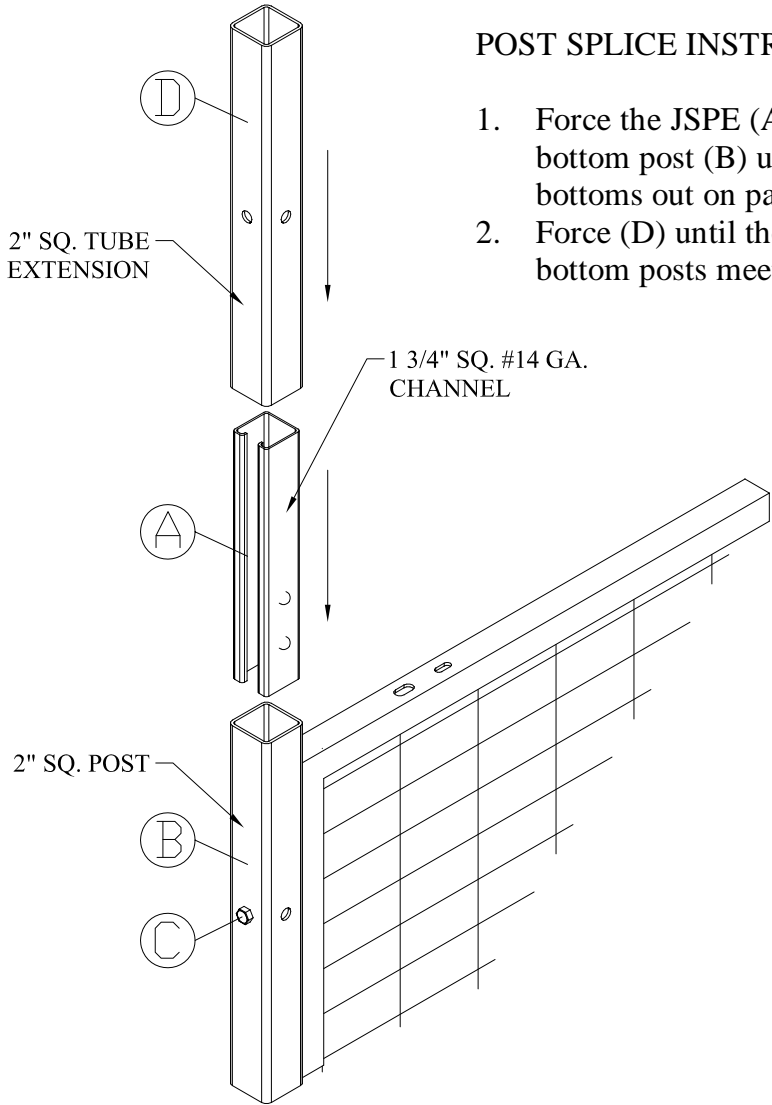

## POST SPLICE INSTRUCTIONS

1. Force the JSPE (A) into the bottom post (B) until it bottoms out on panel bolt (C).
2. Force (D) until the top and bottom posts meet flush.

## DETAIL JSPE

Accessory item used to extend  
height of existing wall.

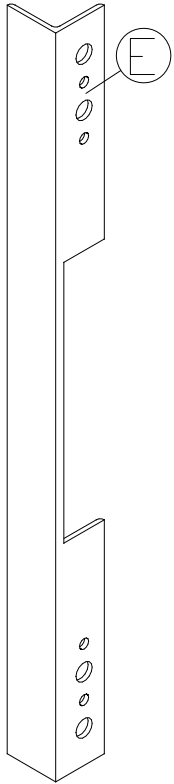

Hinge Door Angle Pick Plate  
Quantity (1)  
Part# HDCPLI

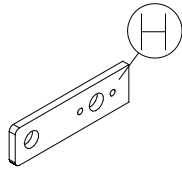

Hinge Door Flat Padlock Lug  
Quantity (1)  
Part# HDLPLLI

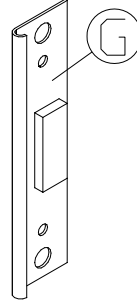

Hinge Door Lock Receiver  
Quantity (1)  
Part# HDLRLI

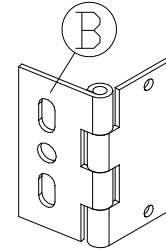

Door Hinge  
Quantity (3)  
Part# HDHG44IPL

**SEE SUPPLIED LOCK MANUFACTURER  
INSTRUCTIONS FOR ASSEMBLY**

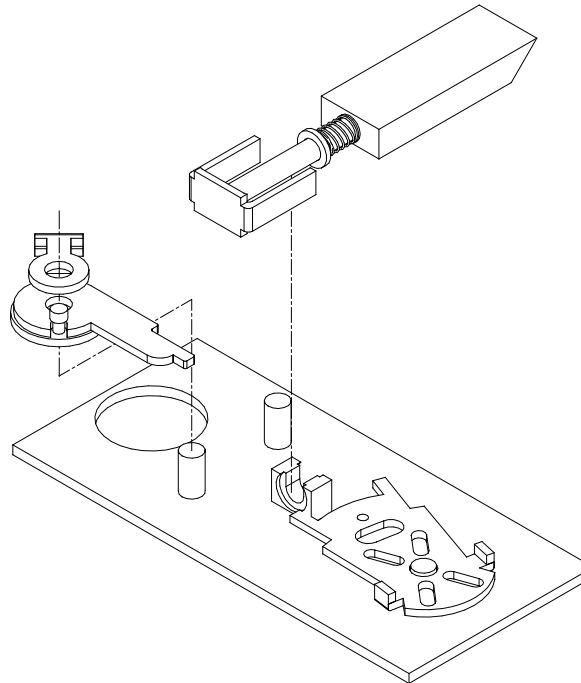

RIGHT HAND ASSEMBLY

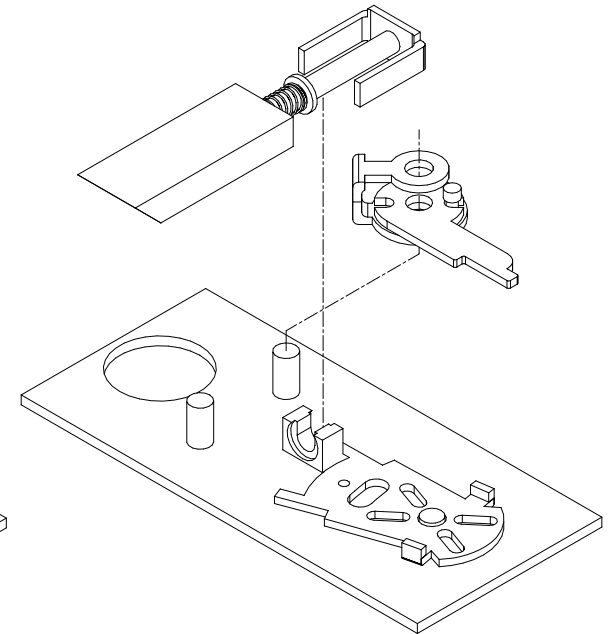

LEFT HAND ASSEMBLY

- HDFSPK - Fastener Pack (Contents Below)
- (25) FSHOPG- Gray Hole Plugs
  - (8) COBO- 3/8" Corner Bolts
  - (8) FS383- 3/8" x 3" Hex Head Cap Screw
  - (6) FS381- 3/8" x 1" Hex Head Cap Screw
  - (30) FS38N- 3/8" Hex Nut
  - (4) FS38STA- 3/8" Wedge Anchor
  - (1) FSTRNSPK- Self-Drilling Screws (25)

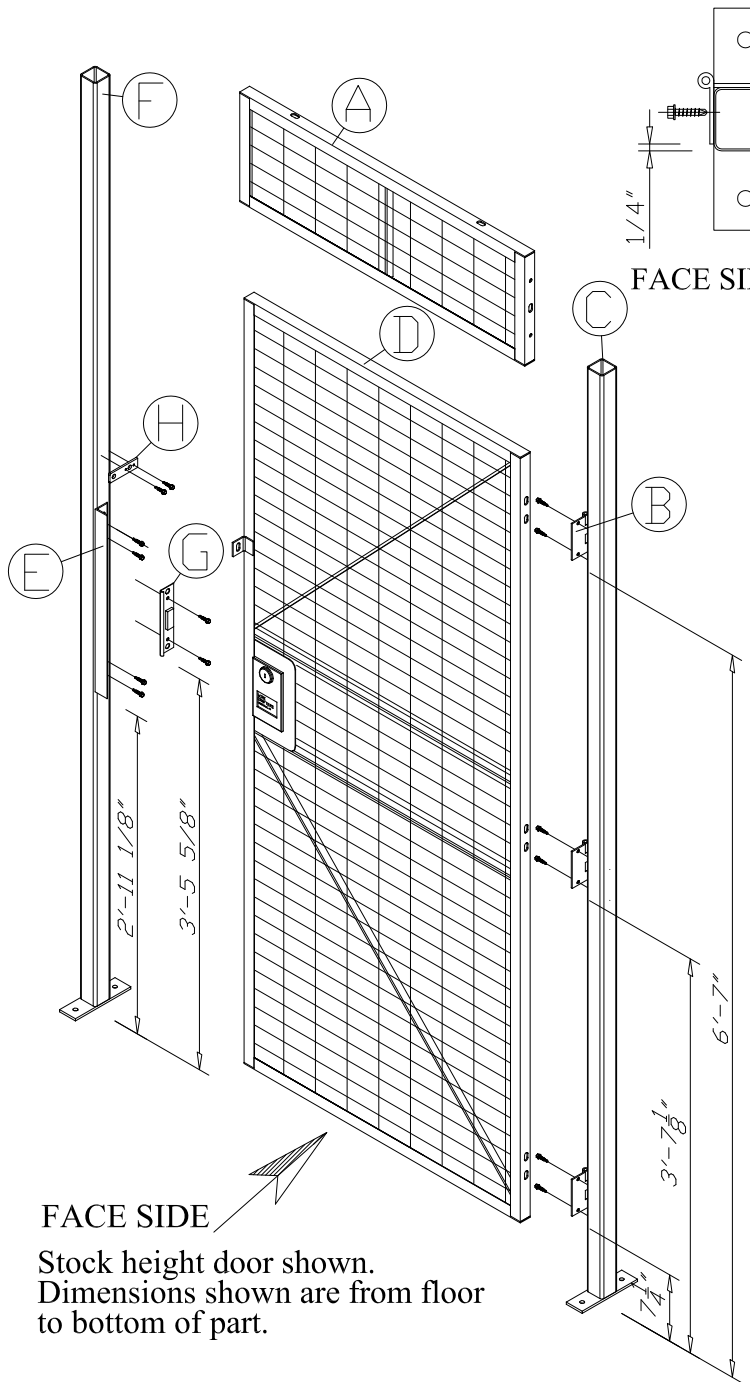

Stock height door shown.  
Dimensions shown are from floor  
to bottom of part.

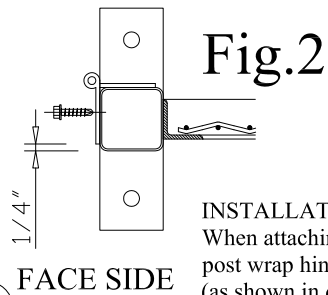

**Fig.2**  
**INSTALLATION TIP:**  
When attaching hinge to door  
post wrap hinge around post  
(as shown in drawing) to set  
proper offset alignment

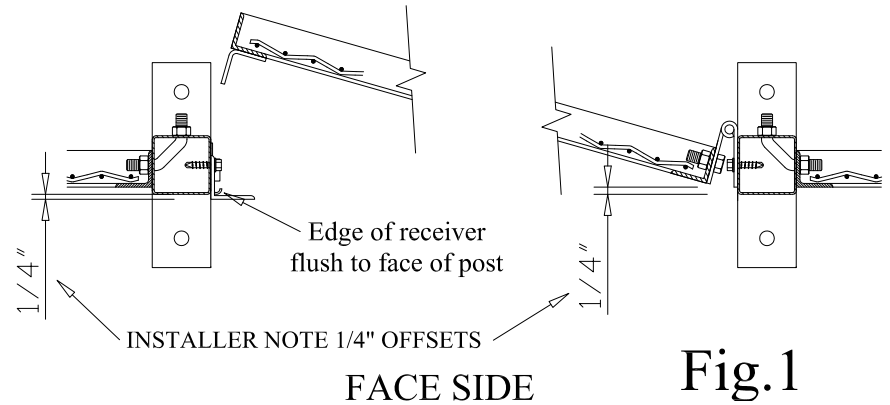

**Fig.1**

### INSTALLER NOTES:

1. Component parts attach using self-drilling screws. Use variable speed screw gun with adjustable clutch or depth locating nose piece. Use care not to over tighten and strip threads. **DO NOT USE IMPACT TYPE GUNS.** Securely clamp part in place before attaching with self drilling screws.
2. The dimensions shown on this page are from the floor to the bottom of the part for standard height 6' 11-3/4" door opening with 3-1/4" sweep space. Use worksheet on page 29 to calculate component locations for non-standard door opening heights or sweep spaces.
3. Partition wall should be set up and anchored to floor, with posts plumb, before attempting to install doors.

### Hinge Door Inside Swing

1. Install transom panel (A) at top of door opening, check opening width at floor, and anchor posts to floor. Check that posts are plumb and opening is square.
2. Attach hinges (B) to door post (C) using two self drilling screws per hinge.
  - a. Note hinge placement offset detailed in Fig.1 and install tip in Fig.2.
  - b. If necessary, remove lower two 3/8" x 3" panel mounting bolts, and replace with corner bolts.
  - c. Stock Doors (3-1/4" sweep sp.), place bottom of hinge 7-1/4", 43 1/8", and 79" from floor.
  - d. Cut off and file smooth any protruding bolt threads.
3. Attach door panel (D) to hinges with two 3/8" x 1" bolts and nuts.
  - a. Set desired sweep space (3-1/4" for stock doors).
4. Attach pick plate (E) to door post (F) using four self drilling screws.
  - a. Note pick plate position offset detailed in Fig 1.
  - b. Bottom of pick plate installs 35-1/8" from floor for stock doors.
  - c. If necessary, remove two 3/8" x 3" panel mounting bolts and replace with corner bolts. Cut off and file smooth any protruding bolt threads.
5. Install cylinder lock (if applicable). See page 6.
6. Attach cylinder lock receiver (G) to door post (F) with two self-drilling screws.
  - a. Rolled side of receiver installs to face side of partition.
  - b. Bottom of receiver installs 41-5/8" from floor for stock doors.
7. Align padlock lug (H) with door padlock lug on door (D) and attach to post (F) with two self drilling screws.
8. Check operation of door, adjust as needed.

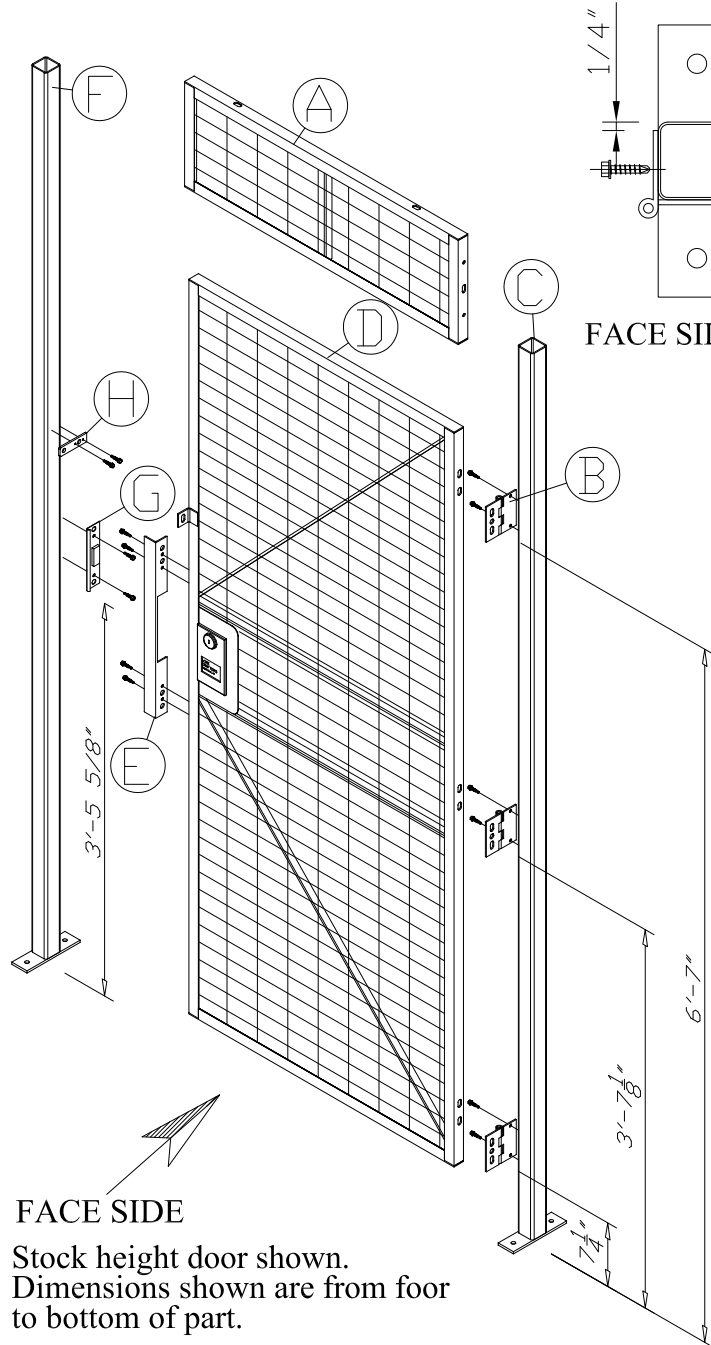
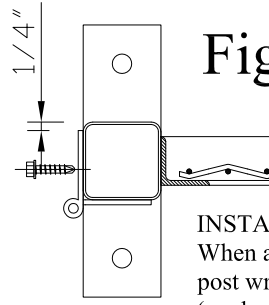

Fig.2



**INSTALLATION TIP:**  
When attaching hinge to door post wrap hinge around post (as shown in drawing) to set proper offset alignment

INSTALLER NOTE 1/4" OFFSET

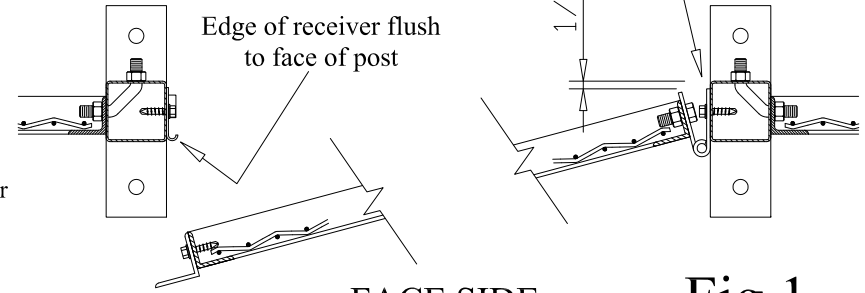

Fig.1

### INSTALLER NOTES:

1. Component parts attach using self-drilling screws. Use variable speed screw gun with adjustable clutch or depth locating nose piece. Use care not to over tighten and strip threads. **DO NOT USE IMPACT TYPE GUNS.** Securely clamp part in place before attaching with self drilling screws.
2. The dimensions shown on this page are from the floor to the bottom of the part for standard height 6' 11-3/4" door opening with 3-1/4" sweep space. Use worksheet on page 29 to calculate component locations for non-standard door opening heights or sweep spaces.
3. Partition wall should be set up and anchored to floor, with posts plumb before attempting to install doors.

### Hinge Door Outside Swing

1. Install transom panel (A) at top of door opening, check opening width at floor, and anchor posts to floor. Check that posts are plumb and opening is square.
2. Attach hinges (B) to door post (C) using two self drilling screws per hinge.
  - a. Note hinge placement offset detailed in Fig 1 and install tip in Fig. 2.
  - b. If necessary remove lower two 3/8" x 3" panel mounting bolts and replace with corner bolts.
  - c. Cut off and file smooth any protruding bolt threads.
  - d. Stock doors (3-1/4" sweep sp.), place bottom of hinge 7-1/4", 43-1/8", and 79" from floor.
3. Attach door panel (D) to hinges with two 3/8" x 1" bolts and nuts.
  - a. Set desired sweep space (3-1/4" for stock doors).
4. Attach pick plate (E) to door panel (D) using four self drilling screws. See Fig.1.
  - a. Pick plate should be centered over lock tongue hole. Bottom of pick plate installs 31-7/8" from bottom of stock doors.
5. Install cylinder lock (if applicable). See page 6.
6. Attach cylinder lock receiver (G) to door post (F) with two self-drilling screws.
  - a. Rolled side of receiver installs to face side of partition.
  - b. Bottom of receiver installs 41-5/8" from floor for stock doors.
  - c. If necessary remove one 3/8" x 3" panel mounting bolts from top of lower panel, and replace with corner bolt. Cut off and file smooth any protruding bolt threads.
7. Align padlock lug (H) with door padlock lug on door (D) and attach to post (F) with two self drilling screws.
8. Check operation of door, adjust as needed.

FACE SIDE

Stock height door shown.  
Dimensions shown are from floor to bottom of part.



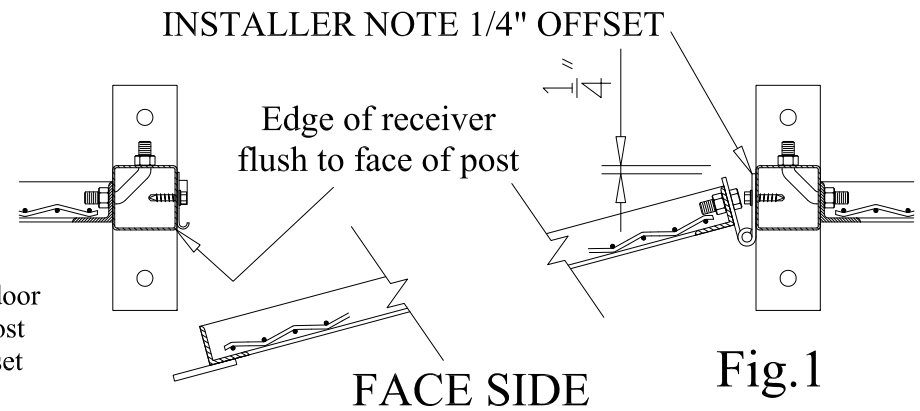
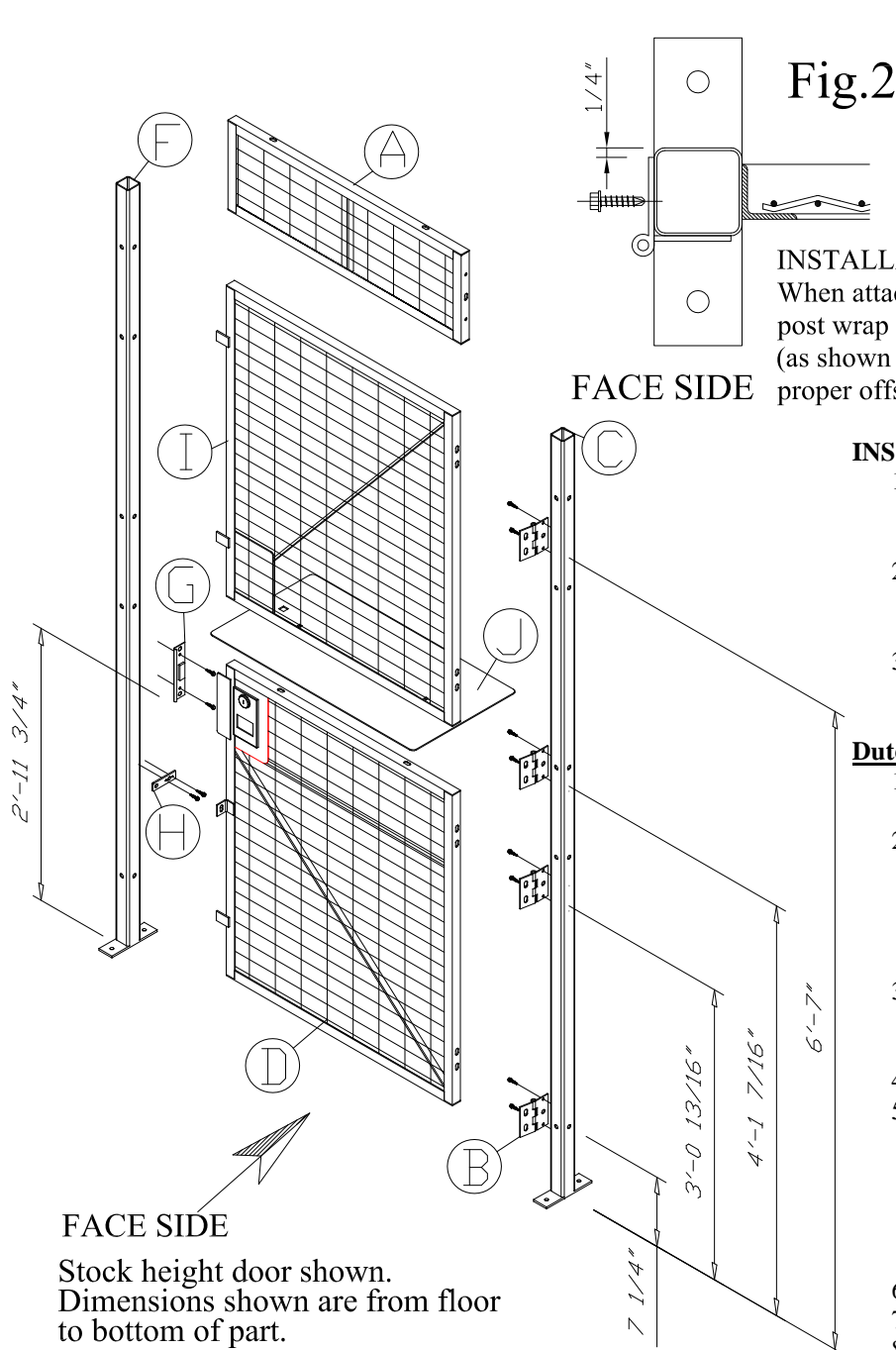

### INSTALLER NOTES:

1. Component parts attach using self-drilling screws. Use variable speed screw gun with adjustable clutch or depth locating nose piece. Use care not to over tighten and strip threads. **DO NOT USE IMPACT TYPE GUNS.** Securely clamp part in place before attaching with self drilling screws.
2. The dimensions shown on this page are from the floor to the bottom of the part for standard height 6' 11-3/4" door opening with 3-1/4" sweep space. Use worksheet on page 29 to calculate component locations for non-standard door opening heights or sweep spaces.
3. Partition wall should be set up and anchored to floor, with posts plumb before attempting to install doors.

### Dutch Door Outside Swing

1. Install transom panel (A) at top of door opening, check opening width at floor, and anchor posts to floor. Check that posts are plumb and opening is square.
2. Attach hinges (B) to door post (C) using two self drilling screws per hinge. Note offset detailed in Fig.1 and install tip Fig.2.
  - a. Stock door (3-1/4" sweep sp.), locate bottom of hinge 7-1/4", 36-13/16", 49-7/16" and 79" from floor. If necessary remove 3/8" x 3" panel mount bolt and replace with corner bolt, cut off and file smooth any protruding bolt threads.
3. Attach door panels (D) & (I) to hinges with two 3/8" x 1" bolts per hinge,
  - a. Set sweep space under lower door panel (3-1/4" for stock doors).
  - b. Set 5/8" gap between door panels.
4. Install cylinder lock (if applicable). See page 6.
5. Attach receiver (G) to door post (F) using two self drilling screws.
  - a. Rolled side of receiver installs to face side of partition.
  - b. Bottom of receiver installs 35-3/4" from floor for stock doors.
  - c. If necessary, remove one 3/8" x 3" panel mounting bolt from top of lower panel and replace with corner bolt.
  - d. Cut off and file smooth any protruding bolt threads.
6. Align padlock lug (H) with padlock lug on door (D) and attach to post (F) with self drilling screws.
7. Attach shelf (J) to top of door panel (D) with two 3/8" x 1" carriage bolts.
8. Check operation of door, adjust as needed.

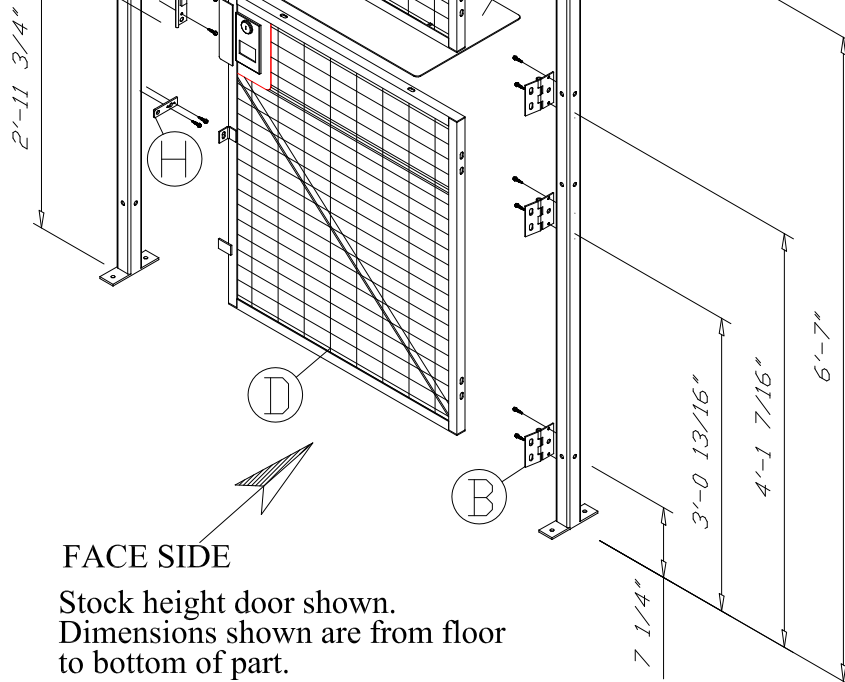

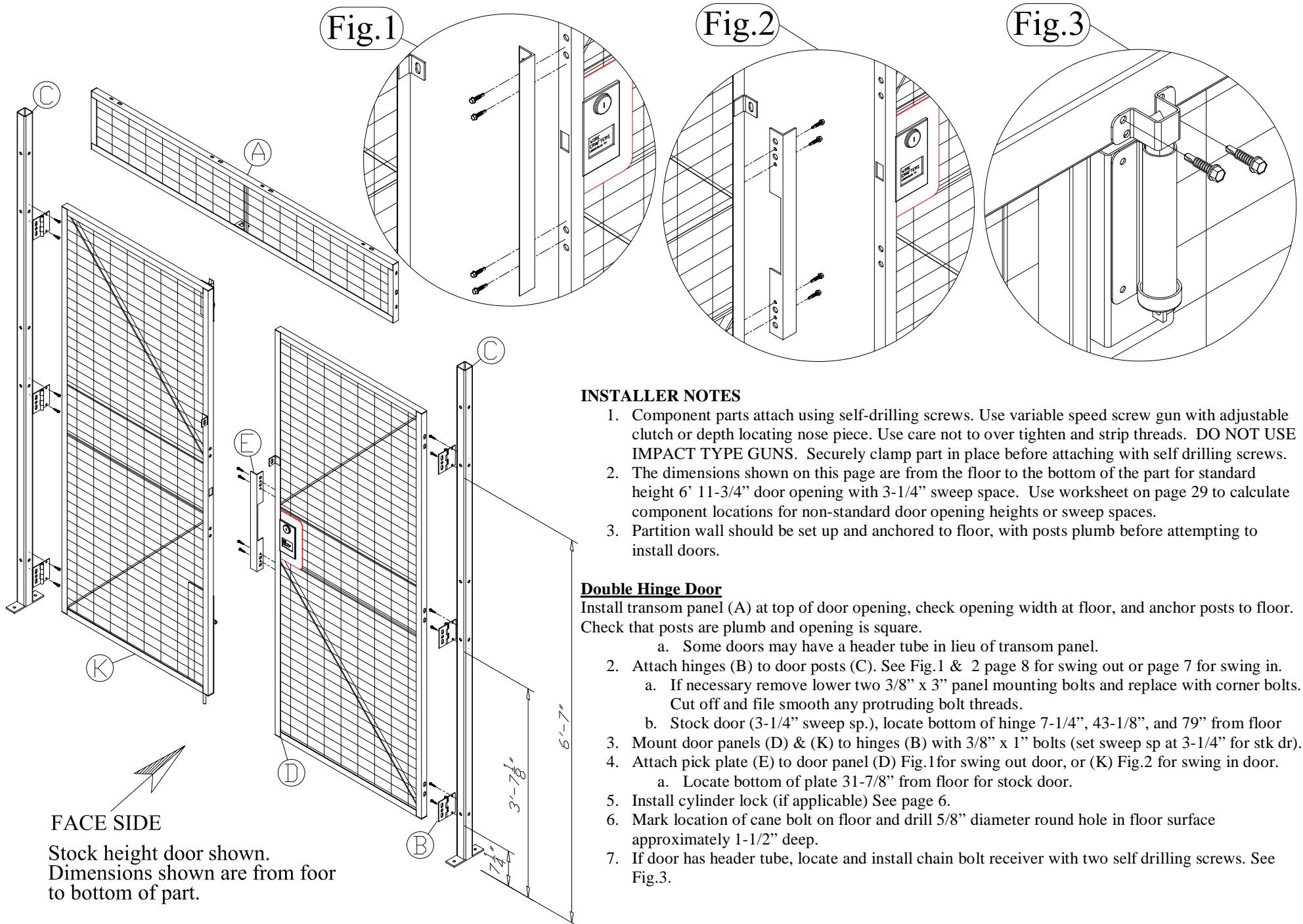

## INSTALLER NOTES

- Component parts attach using self-drilling screws. Use variable speed screw gun with adjustable clutch or depth locating nose piece. Use care not to over tighten and strip threads. **DO NOT USE IMPACT TYPE GUNS.** Securely clamp part in place before attaching with self drilling screws.
- The dimensions shown on this page are from the floor to the bottom of the part for standard height 6' 11-3/4" door opening with 3-1/4" sweep space. Use worksheet on page 29 to calculate component locations for non-standard door opening heights or sweep spaces.
- Partition wall should be set up and anchored to floor, with posts plumb before attempting to install doors.

## Double Hinge Door

Install transom panel (A) at top of door opening, check opening width at floor, and anchor posts to floor. Check that posts are plumb and opening is square.

- Some doors may have a header tube in lieu of transom panel.
- Attach hinges (B) to door posts (C). See Fig.1 & 2 page 8 for swing out or page 7 for swing in.
    - If necessary remove lower two 3/8" x 3" panel mounting bolts and replace with corner bolts. Cut off and file smooth any protruding bolt threads.
    - Stock door (3-1/4" sweep sp.), locate bottom of hinge 7-1/4", 43-1/8", and 79" from floor
  - Mount door panels (D) & (K) to hinges (B) with 3/8" x 1" bolts (set sweep sp at 3-1/4" for stk dr).
  - Attach pick plate (E) to door panel (D) Fig.1 for swing out door, or (K) Fig.2 for swing in door.
    - Locate bottom of plate 31-7/8" from floor for stock door.
  - Install cylinder lock (if applicable) See page 6.
  - Mark location of cane bolt on floor and drill 5/8" diameter round hole in floor surface approximately 1-1/2" deep.
  - If door has header tube, locate and install chain bolt receiver with two self drilling screws. See Fig.3.

FACE SIDE

Stock height door shown.  
Dimensions shown are from floor to bottom of part.

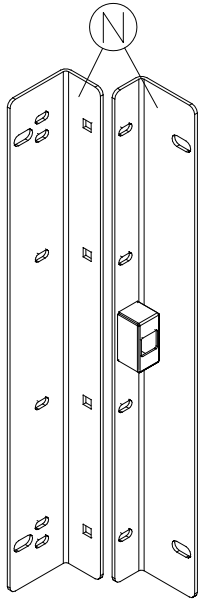

SDRECA SDRECB  
Slide Door Receiver  
Quantity (1)  
Part# SDREC

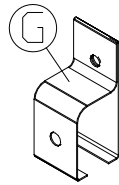

Slide Door Track Bracket  
Quantity (2)  
Part# SDTCBKT

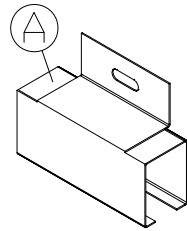

Splice Track Bracket  
Quantity (1)  
Part# SDTJBKT

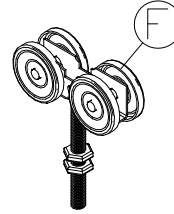

4 Wheel Trolley Truck  
Quantity (2)  
Part# SDTT4WH

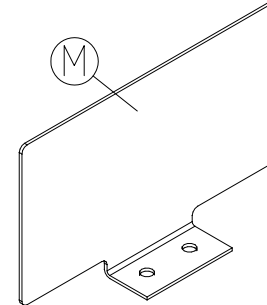

Door Guide  
Quantity (1)  
Part# SDDGCH18

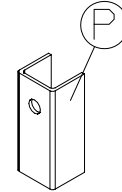

1 11/16" x 1 1/2" Channel 4" Lg.  
Quantity (1)  
Part# SDSDT

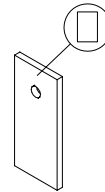

Slide Door Shim  
Quantity (4)  
Part# SDSCH412238

**SEE SUPPLIED LOCK**  
**MANUFACTURER INSTRUCTIONS FOR**  
**ASSEMBLY**

**SDFSPK - Slide Door Fastener Pack (Contents Below)**

- (35) FSHOPG- Gray Hole Plugs
- (2) COBO- 3/8" Corner Bolts
- (9) FS383- 3/8" x 3" Hex Head Cap Screw
- (2) FS381- 3/8" x 1" Hex Head Cap Screw
- (17) FS38N- 3/8" Hex Nut
- (6) FS38STA- 3/8" Wedge Anchor
- (6) FS38FW- 3/8" Flat Washer
- (1) FS38112- 3/8" x 1 1/2" Hex Head Cap Screw
- (1) FS38212- 3/8" x 2 1/2" Hex Head Cap Screw
- (1) FSTRNSPK- 1/4" x 1" Self-Drilling Screws (25) & 5/16" X 1" Carriage Bolts (4)

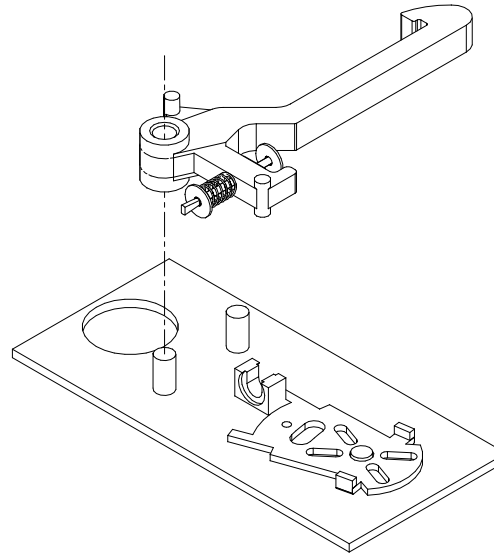

RIGHT HAND ASSEMBLY

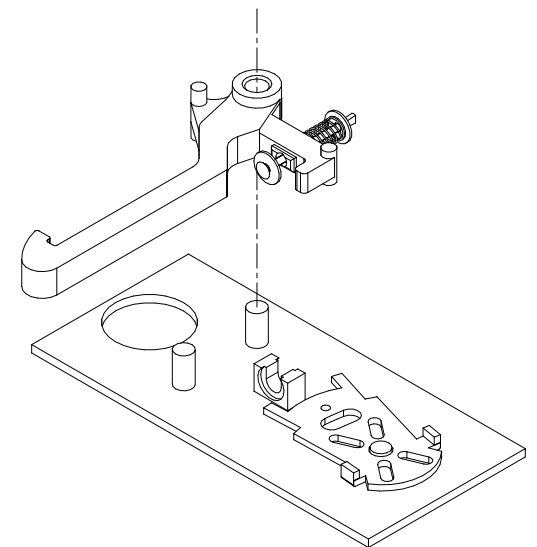

LEFT HAND ASSEMBLY

## INSTALLER NOTES

1. Doors wider than 5' are made up of multiple door panels (see page 16), and use two pieces of track spliced at Splice Track Bracket (A).
2. Component parts attach using self-drilling screws. Use variable speed screw gun with adjustable clutch or depth locating nose piece. Use care not to over tighten and strip threads. **DO NOT USE IMPACT TYPE GUNS.** Securely clamp part in place before attaching with self drilling screws.
3. Partition wall should be set up and anchored to floor. It is **CRITICAL** that posts are plumb and in line. Door opening should be square.

## Outside Slide Door

1. Check that door posts are anchored and plumb.
2. Using a 3/8" x 3" bolt, install Splice Track Bracket (A) on face side of door post (B) opposite door receiver post (C). Note: if enclosure has ceiling use a 3/8" x 1" bolt to attach bracket see Fig.1.
3. Place two 4 wheel trolley trucks (F) into track (D). Using one 3/8" x 1" bolt, attach track bracket (G-1) to track.
  - a. Check that trucks roll freely in track.
4. Slide open end of track (D) into Splice Track Bracket (A). Using one 3/8" x 3" bolt, attach track bracket (G-1) to receiver post (C) see Fig 2.
5. Invert Track Bracket (G-2) and attach to far end of Track (D) using one 3/8" x 1" bolt. If end of track aligns with post, do not invert track bracket.
  - a. For doors wider than 5'
    - i. Attach inverted bracket to far end of second track section.
    - ii. Slide open end of second track section (D) into open end of Splice Track Bracket (A).
6. Using one 3/8" x 1-1/2" bolt and two slide door shims (O), attach the inverted track bracket on the far end of Track (D) to the wire mesh panel.
  - a. Per Fig. 3 place one flat slide door shim between the Track Bracket (G-2) and the mesh, and the other Slide Door Shim on the inside of the mesh and fasten in place with one 3/8" x 1-1/2" bolt and hex nut. **TRACK MUST BE LEVEL.**
  - b. Should Track Bracket (G-2) align with post, attach upright track bracket to post with 3/8" bolt.
7. For doors wider than 5' or taller than 8', assemble door panels to form door assembly. See Slide Door Panel Assembly page 16.
8. Hang door (I) on Trolley Trucks.
  - a. Two 9/16" round holes on top of door assembly match trolley bolts.
  - b. Trolley bolts should have one nut above and below door frame; upper "jam" nut should be backed off until door operation is finalized.
9. Lag door guide (M) to floor with two floor anchors see Fig 4.
10. Raise door to desired sweep space using lower trolley nut.
  - a. Stock doors without lower angle cover bar have 3-1/4" sweep space.
  - b. Stock doors with lower angle cover bar have 1-3/4" sweep space.
  - c. Door must be level for proper operation.
11. Door should slide freely, if not check that trolley trucks are properly aligned in track.
12. If applicable, install cylinder lock in door, see page 11.
13. Install Lock Receiver (N). See Fig 5. and slide door receiver instructions on page 17.
14. Fine tune door by tightening/loosening trolley truck nuts.
  - a. When door operates smoothly and locks consistently, tighten top jam nut.
  - b. Be sure not to cock trolleys sideways when tightening jam nut. It may be necessary to hold bolt with pliers while tightening jam nut.

NOTE: 10' High Doors, See Page 16

PARTIAL MESH SHOWN FOR CLARITY

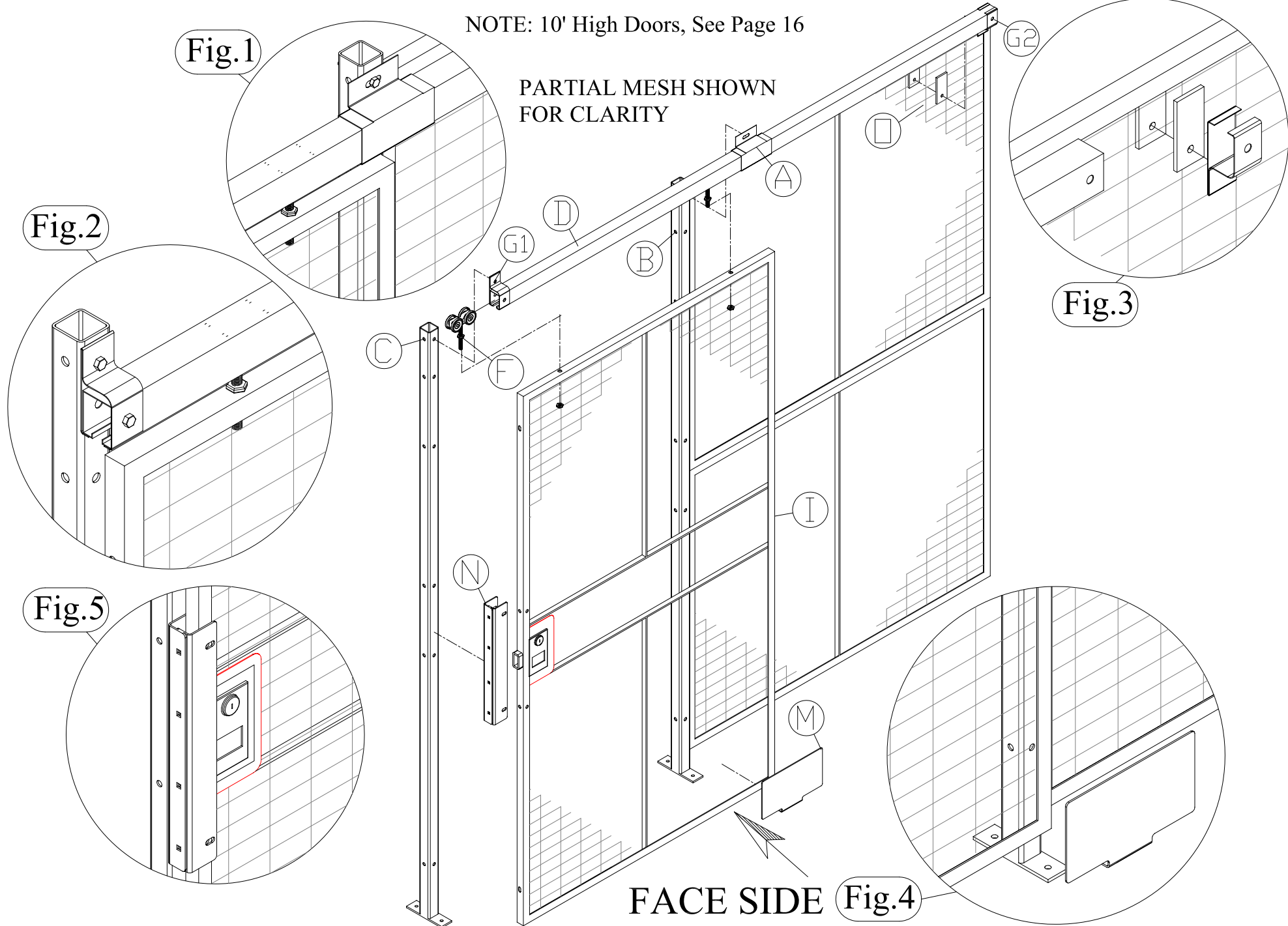

## INSTALLER NOTES

1. Doors wider than 5' are made up of multiple door panels (see page 16), and use two pieces of track spliced at Track Bracket (A).
2. Component parts attach using self-drilling screws. Use variable speed screw gun with adjustable clutch or depth locating nose piece. Use care not to over tighten and strip threads. **DO NOT USE IMPACT TYPE GUNS.** Securely clamp part in place before attaching with self drilling screws.
3. Partition wall should be set up and anchored to floor. It is **CRITICAL** that posts are plumb and in line. Door opening should be square.

## Inside Slide Door

1. Check that door posts are anchored and plumb.
2. Using a 3/8" x 3" bolt and one Slide Door Shim(O), install Splice Track Bracket (A) on inside of door post (B) opposite door receiver post (C). Place the shim between the bracket and the post. Note: If enclosure has ceiling, use a 3/8" x 1" bolt to attach bracket see Fig.1.
3. Place two 4 wheel trolley trucks (F) into track (D). Using one 3/8" x 1" bolt attach track bracket (G1) to track.
  - a. Check that trucks roll freely in track.
4. Slide open end of track (D) into Splice Track Bracket (A). Using one 3/8" x 3" bolt and one Slide Door Shim (O), attach track bracket (G1) to inside of receiver post (C) see Fig 2.
5. Invert Track Bracket (G2) and attach to far end of Track (D) using one 3/8" x 1" bolt. If end of track aligns with post, do not invert track bracket.
  - a. For doors wider than 5'
    - i. Attach inverted bracket to far end of second track section.
    - ii. Slide open end of second track section (D) into open end of Splice Track Bracket (A).
6. Using one 3/8" x 2-1/2" bolt, one slide door shim (O) and one 2" Slide Door Spacer (P), attach the inverted track bracket on the far end of Track (D) to the wire mesh panel. **TRACK MUST BE LEVEL.**
  - a. Per Fig. 3 place one 2" Slide Door Spacer between the Track Bracket and the mesh, and the Slide Door Shim on the outside of the mesh and fasten in place with one 3/8" x 2-1/2" bolt and hex nut.
  - b. Should Track Bracket (G-2) align with post, attach upright track bracket to post with 3/8" bolt.
7. For doors wider than 5' or taller than 8', assemble door panels to form door assembly. See Slide Door Panel Assembly page 16.
8. Hang door (I) on Trolley Trucks.
  - a. Two 9/16" round holes on top of door assembly match trolley bolts.
  - b. Trolley bolts should have one nut above and below door frame; upper "jam" nut should be backed off until door operation is finalized.
9. Lag door guide (M) to floor with two floor anchors see Fig 4.
10. Raise door to desired sweep space using lower trolley nut.
  - a. Stock doors without lower angle cover bar have 3-1/4" sweep space.
  - b. Stock doors with lower angle cover bar have 1-3/4" sweep space.
  - c. Door must be level for proper operation.
11. Door should slide freely. If not check that trolley trucks are properly aligned in track.
12. If applicable, install cylinder lock in door, see page 11.
13. Install Lock Receiver (N). See Fig.5 and Slide Door Receiver instruction on page 17.
14. Fine tune door by tightening/loosening trolley truck nuts.
  - a. When door operates smoothly and locks consistently, tighten top jam nut.
  - b. Be sure not to cock trolleys sideways when tightening jam nut. It may be necessary to hold bolt with pliers while tightening jam nut.

NOTE: 10' High Doors, See Page 16

PARTIAL MESH SHOWN  
FOR CLARITY

Fig.1

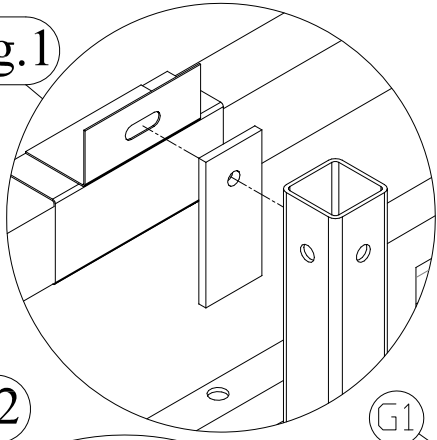

Fig.2

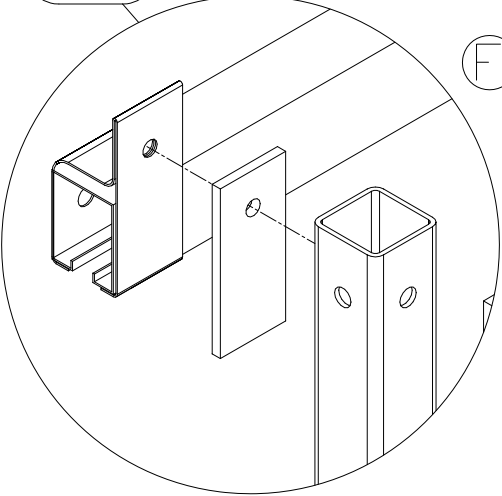

Fig.5

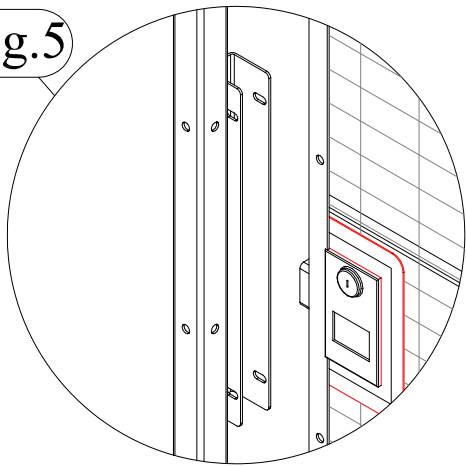

Fig.3

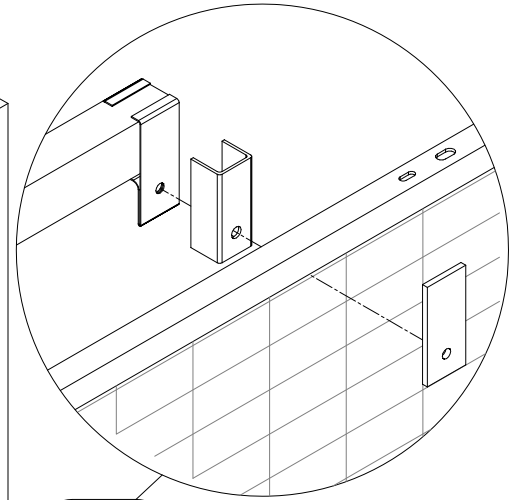
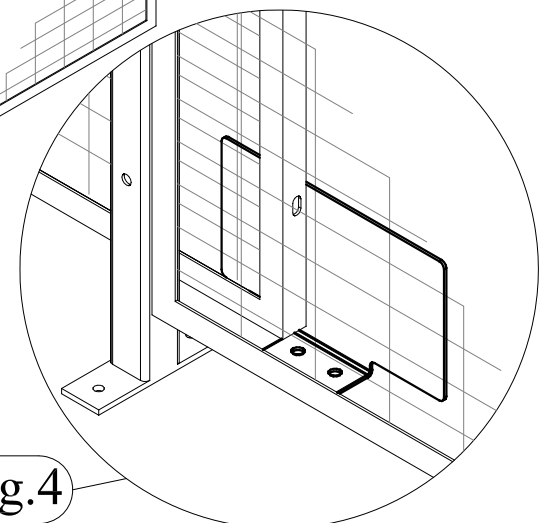
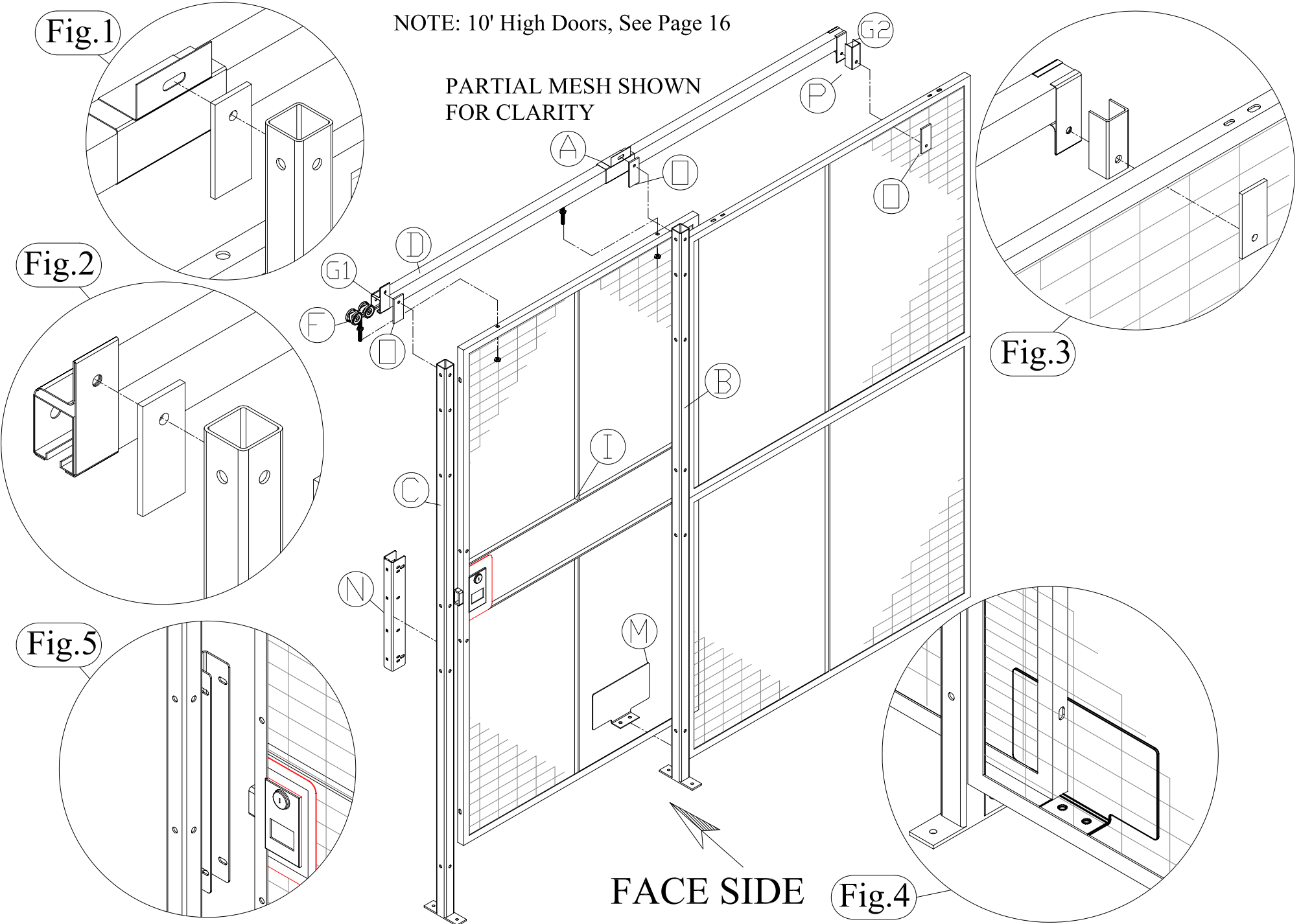

Fig.4



FACE SIDE





# WireCrafters

## 6' or Wider Slide Door Panel Assembly

NOTE: Part (C) DEP for 10'  
High Doors Only

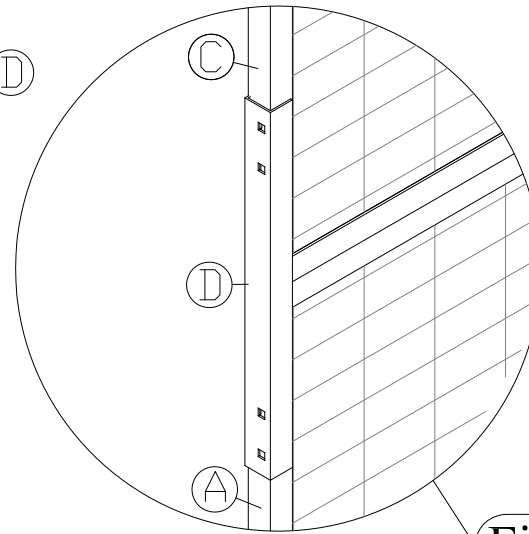
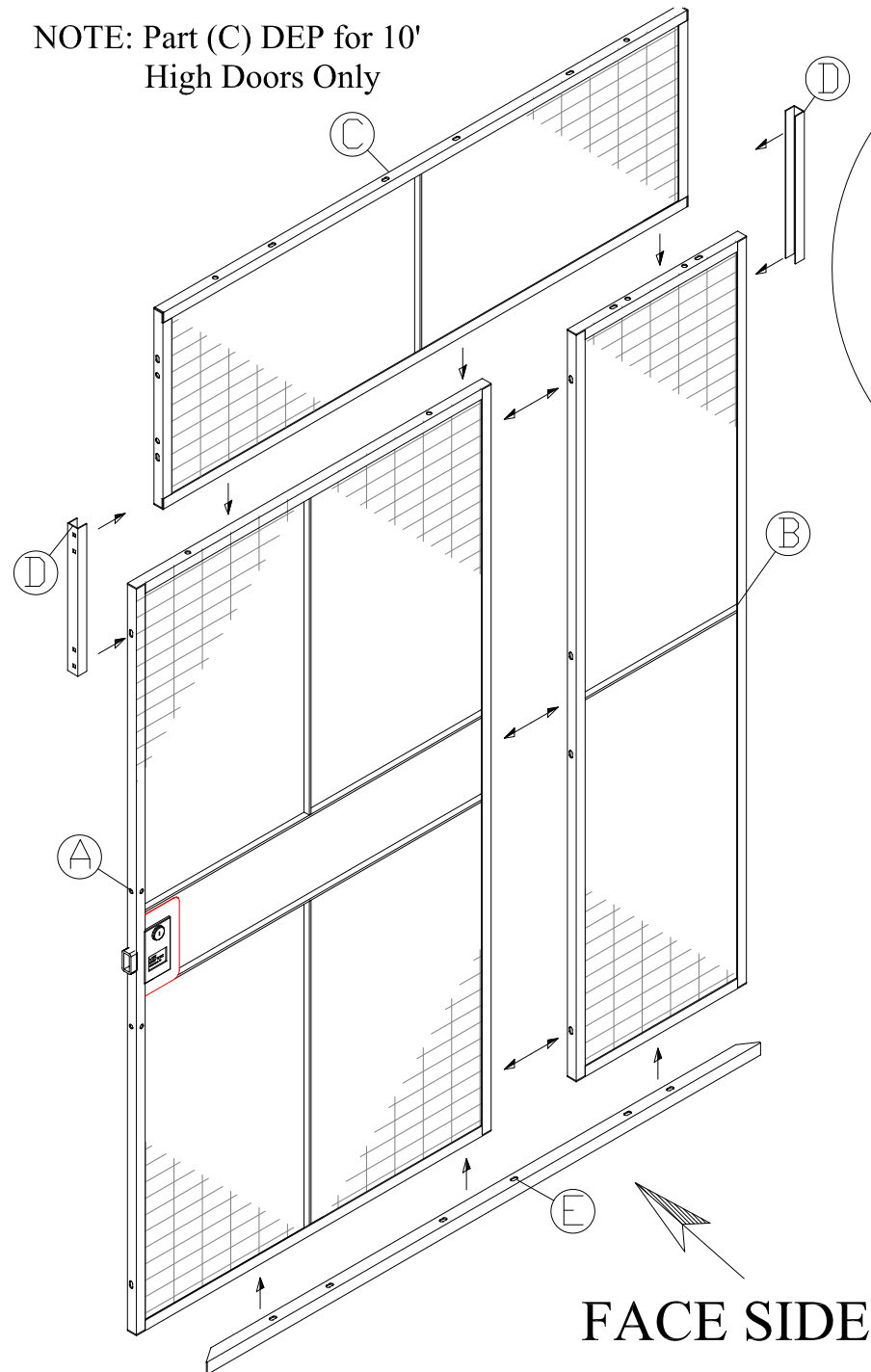

10' High Doors or Taller

Fig. 1

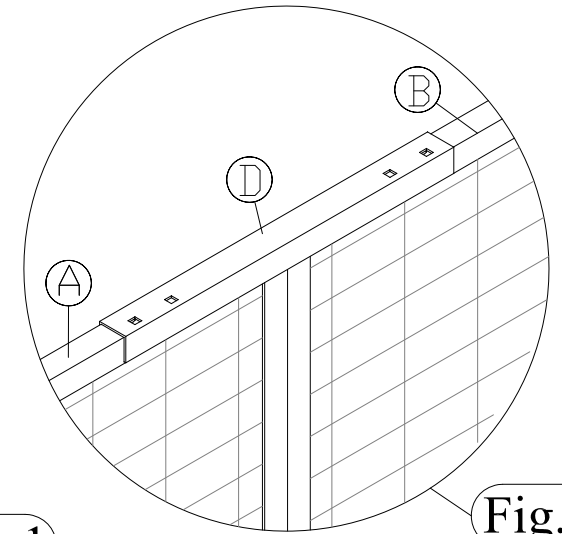

8' High Doors or Shorter

Fig. 2

### SLIDE DOOR PANEL ASSEMBLY

1. Attach door panel (A) to leaf panel(s) (B) with 3/8" x 1" bolts.
  - a. 10' wide doors have 4' 2" wide door panel, 4' wide leaf panel, and 2' wide leaf panel.
2. For 10' high doors, attach 2' high DEP panel (C)
  - a. Attach two 18" DEP Channels (D) with 3/8" x 1" carriage bolts to splice connection between door and DEP see Fig. 1.
3. For 8' high doors, attach one 18" DEP Channel (D) per joint, to top frame with 3/8" x 1" carriage bolts, see Fig. 2.
4. Attach lower angle cover bar (E) to bottom of door with 3/8" bolts and nuts.



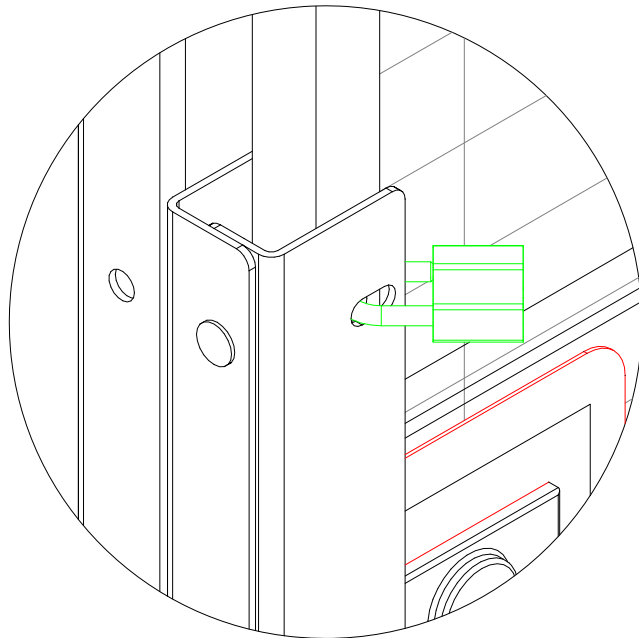

## TYPICAL PADLOCK LUG CONNECTION

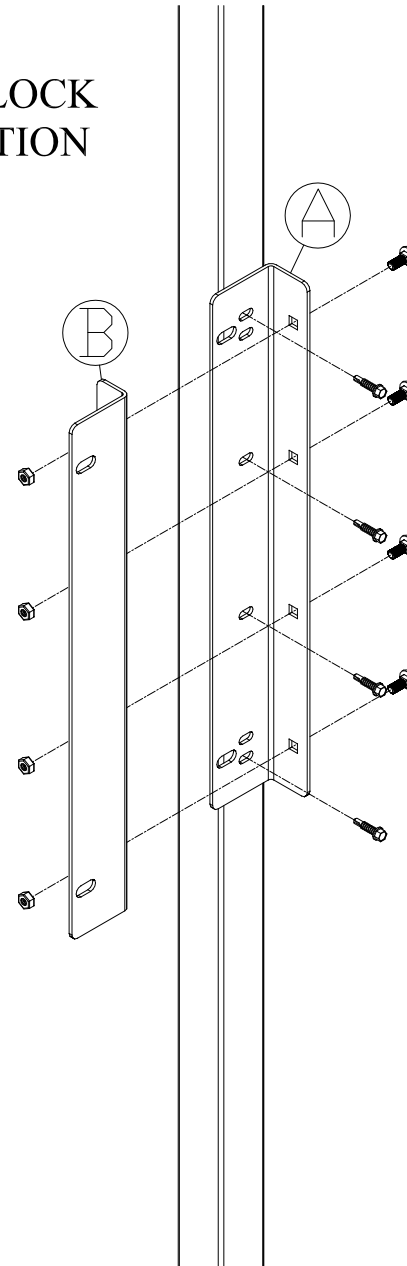

Note:

Component parts attach using self-drilling screws. Use variable speed screw gun with adjustable clutch or depth locating nose piece when installing self-drilling screws. **DO NOT USE IMPACT TYPE GUNS.**

### RECEIVER LOCATION :

1. Measure from floor to center of the installed slide door's lock opening—normally 49" for stock doors.
  - a. Be sure proper sweep space has been set before measuring.
2. Subtract 10" from the above measurement to get the dimension from the floor to the bottom of Lock Receiver (A)—normally 39" for stock doors.
  - a. Mark post.
3. Place leg of Lock Receiver (A) with eight slotted holes against receiver post.
  - a. See Fig.1 for receiver (A) orientation.
  - b. Align bottom of receiver with spot marked in Step 2 above.
4. Align opposing leg of Lock Receiver (A) with square holes with edge of post.
5. Attach Lock Receiver (A) to door post with four self-drilling screws.
6. Using four 5/16" x 1" carriage bolts, securely attach Lock Receiver (B) to (A).
7. Fine tune door up or down so that the door's tubular lock tongue guard overlaps lock receiver tube. **DOOR MUST BE LEVEL.**

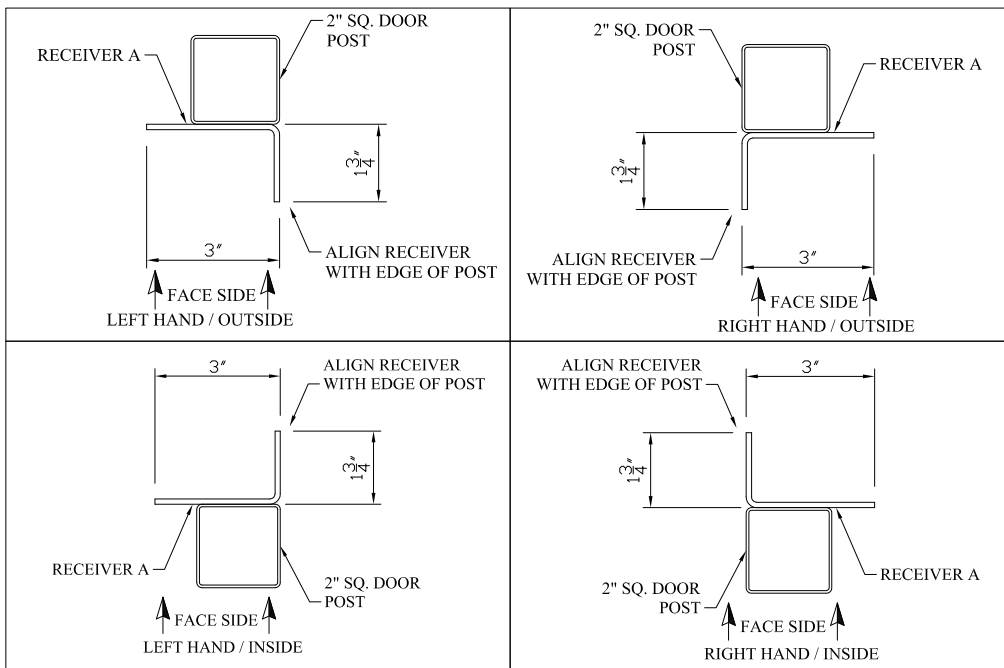
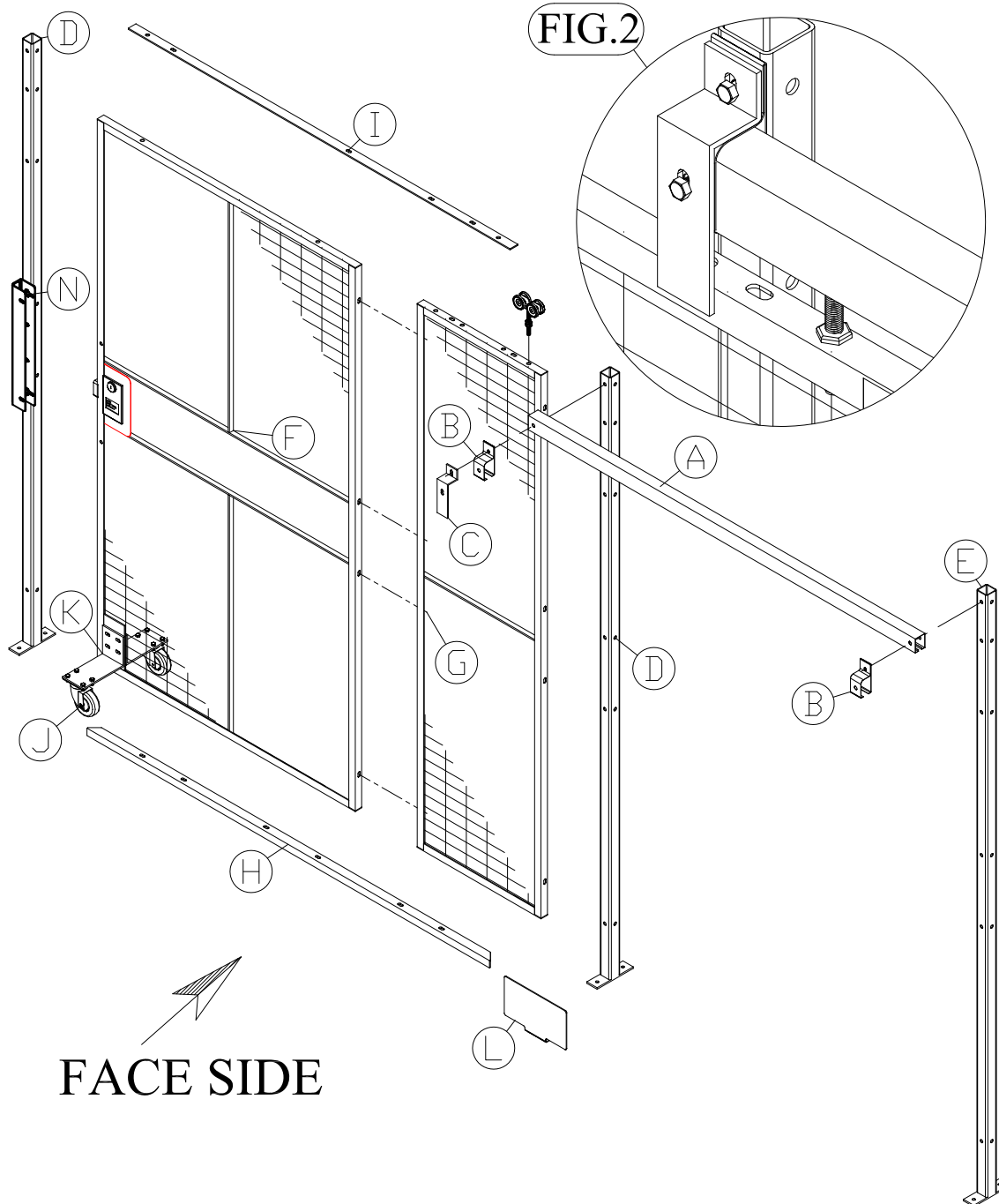

Fig.1



## INSTALLER NOTES

1. Component parts attach using self-drilling screws. Use variable speed screw gun with adjustable clutch or depth locating nose piece. Use care not to over tighten and strip threads. **DO NOT USE IMPACT TYPE GUNS.** Securely clamp part in place before attaching with self drilling screws.
2. Partition wall should be set up and anchored to floor. It is **CRITICAL** that posts are plumb and in line. Door opening should be square.

## Tunnel Door

1. Check that all posts are anchored and plumb.
2. Place one four wheeled trolley truck in track (A).
3. Using 3/8" x 1" bolt, attach Track Bracket (B) and Z-Bracket (C) to leading end of track (A) see Fig.2.
4. Attach second Track Bracket (B) to far end of track (A) using 3/8" x 1" bolt.
5. Mount track assembly to Posts (D) and (E) with 3/8" x 3" bolts and nuts.
  - a. If enclosure has ceiling use 3/8" x 1" bolts to attach track brackets.
6. Assemble door panels if applicable.
  - a. Bolt door panel (F) to door leaf (G). (Some doors have multiple panels.)
  - b. Bolt Angle Cover Bar (H) to bottom of door panels (F) & (G).
  - c. Bolt Flat Cover Bar (I) to top of door panels (F) and (G).
7. Install cylinder lock (if applicable). See page 11 for instructions.
8. Mount casters (J) to caster plates (K), (two per door) with 5/16" x 1" bolts.
9. Mount caster plate assemblies to door panel (F) using 3/8" x 1 1/2" bolts (use 2 washers for each bolt) see Fig. 1.
10. Bolt trailing end of door to trolley inside of track (A) so that door is level.
11. Lag Door Guide (L) to floor using two 3/8" anchors.
12. Mount receiver (N). See page 17 for details.
13. Check door operation so that it rolls smoothly, and latch engages and locks
  - a. Adjust caster plates and trolley bolt if necessary.
14. Tighten upper jam nut on trolley truck
  - a. Do not cock trolley in track when tightening jam nut. It may be necessary to hold bolt while tightening.

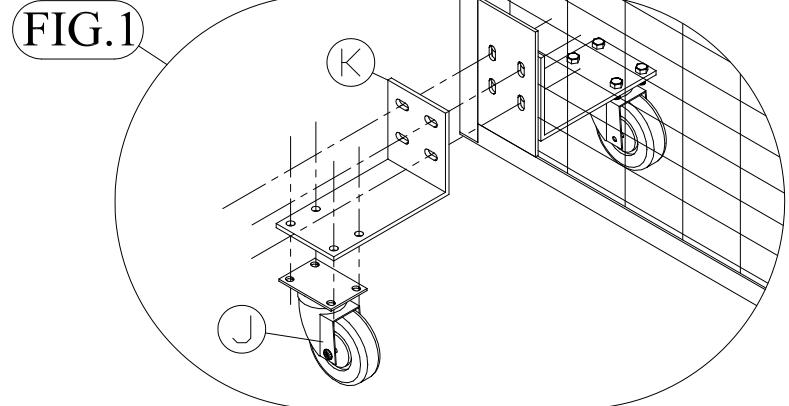

FACE SIDE

### INSTALL SLOTTED ANGLE

- 1. Cut slotted angle 1/2" shorter than panel width.
- 2. Install slotted angle on the top panel with one leg up to the inside of the enclosure or wall using 3/8" x 1" bolts.
- 3. Lift panels into place, face side up, and bolt to slotted angle with 3/8" x 1" bolts.

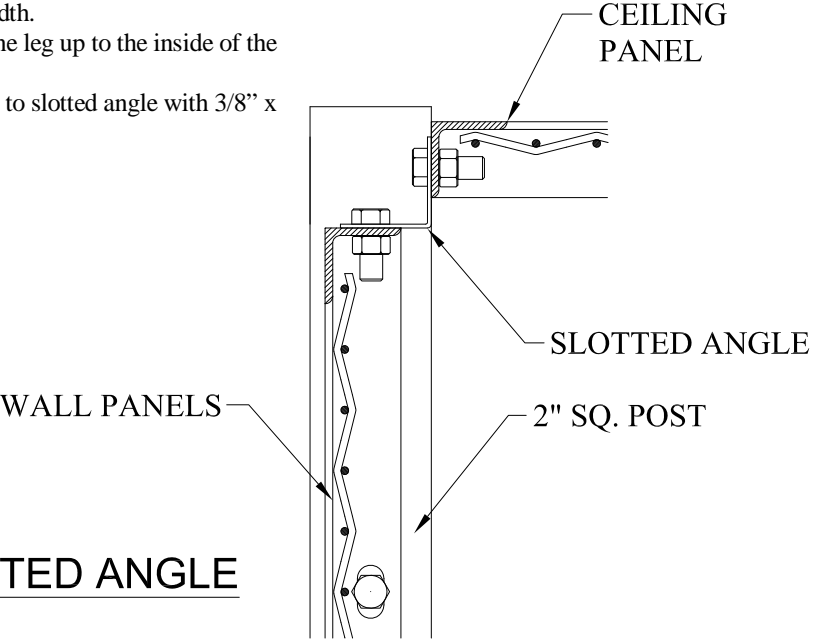
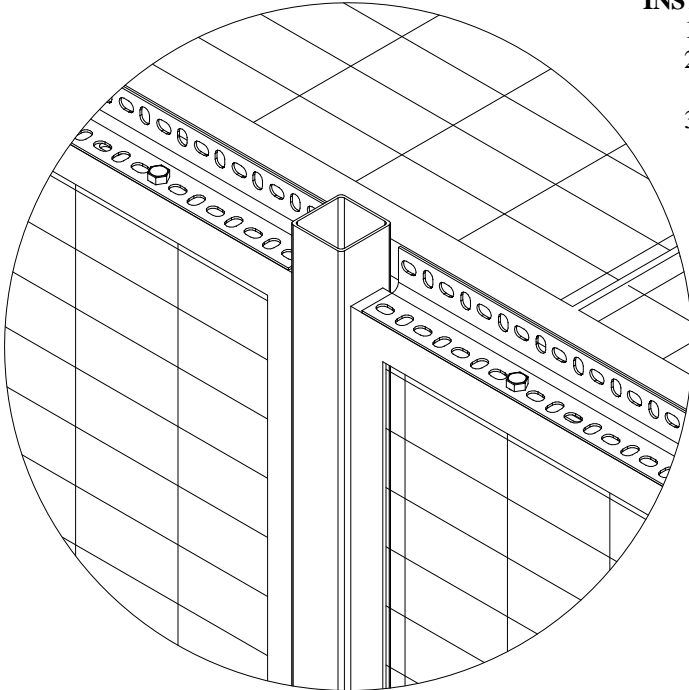

SLOTTED ANGLE

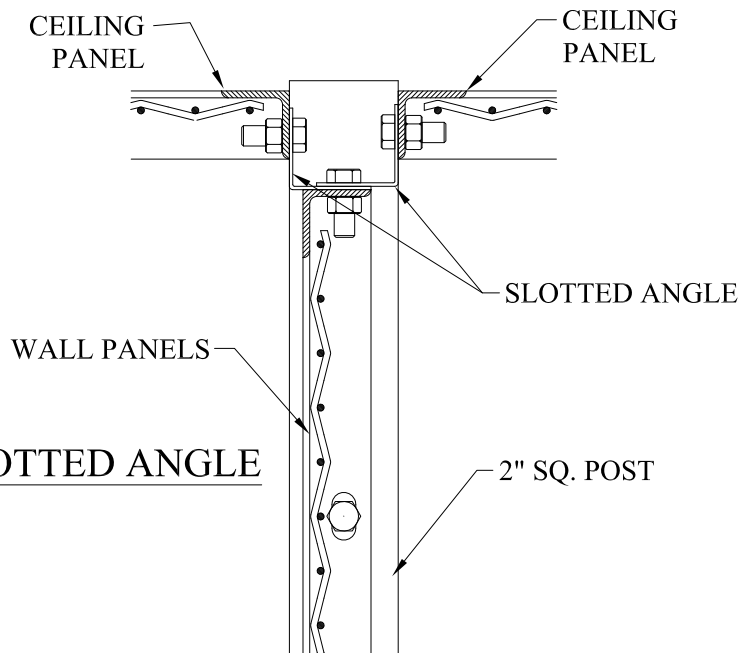
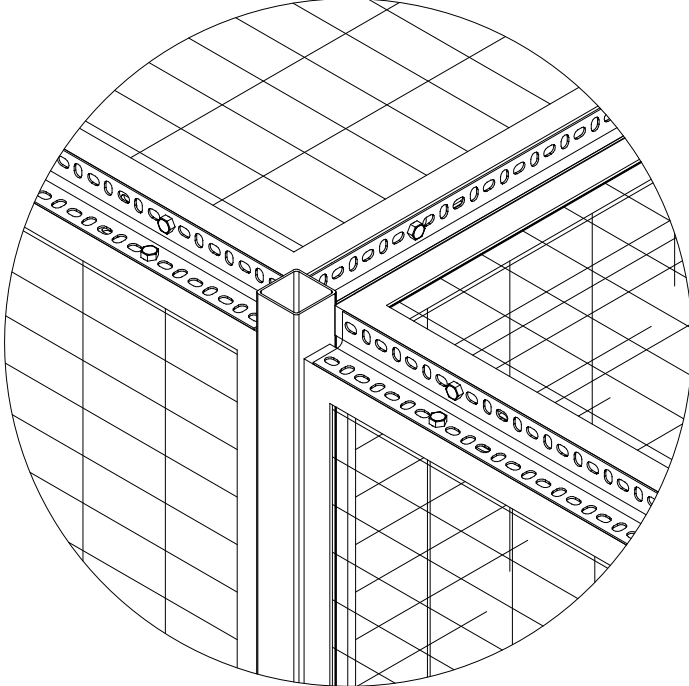

DOUBLE-SLOTTED ANGLE

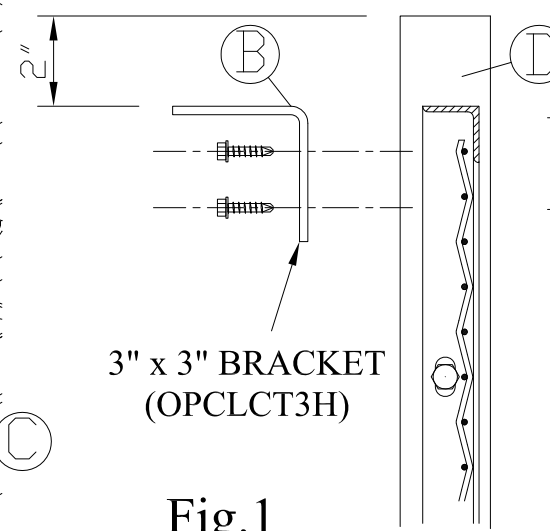
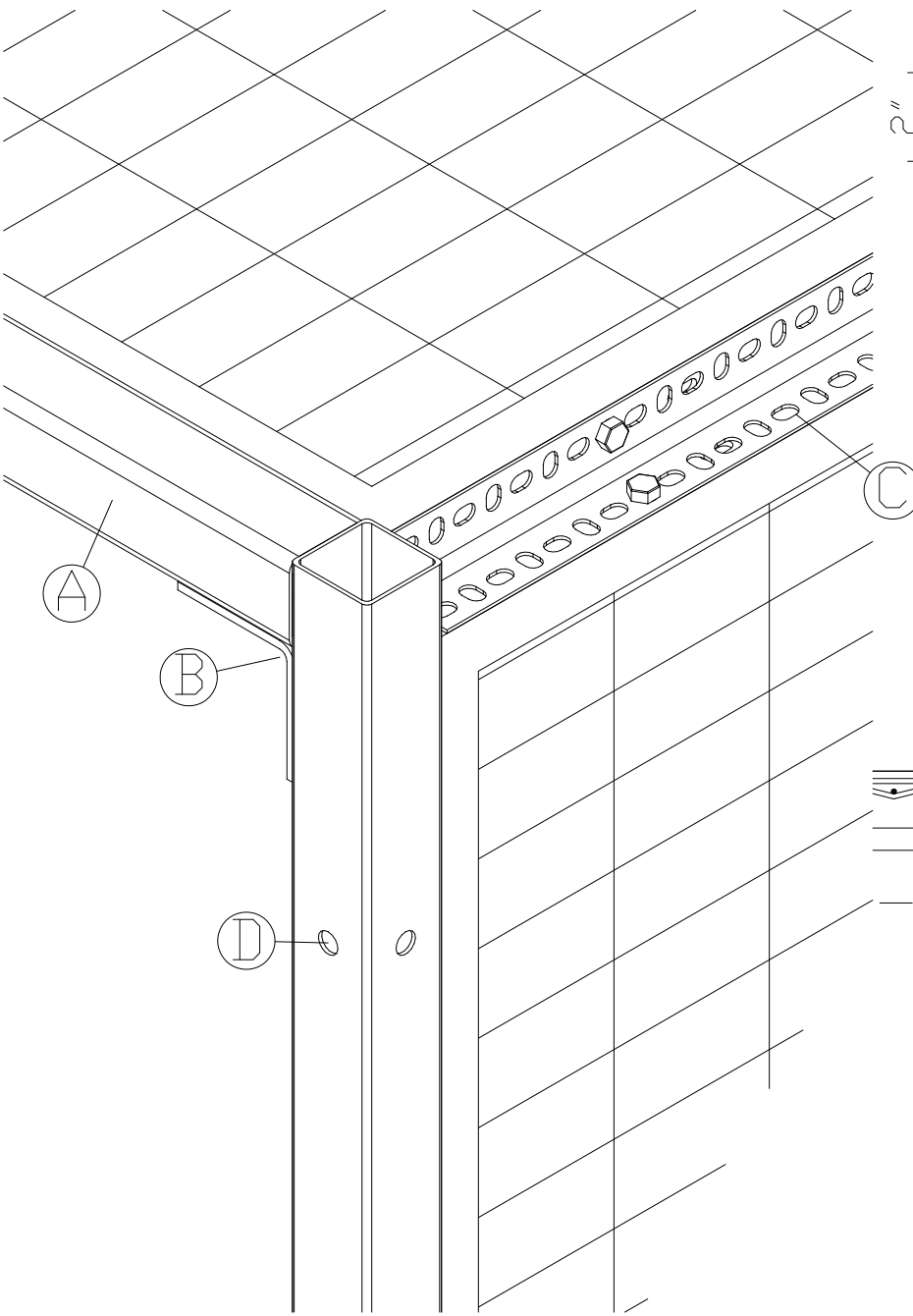

Fig. 1

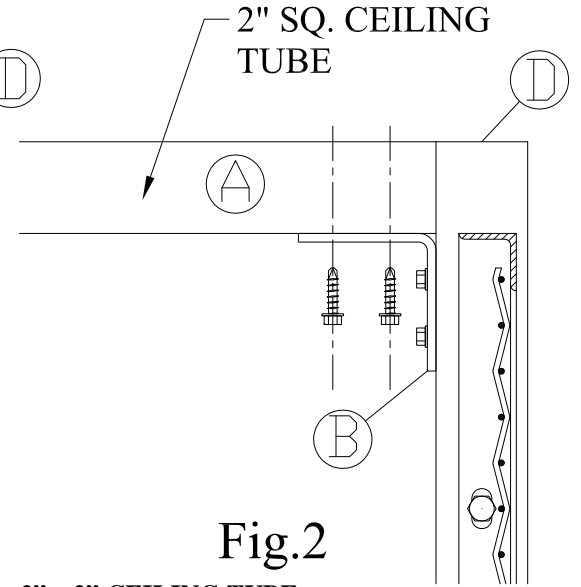

Fig. 2

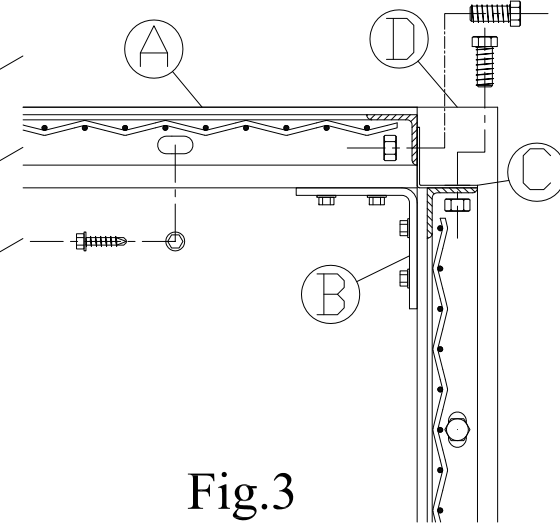

Fig. 3

### 2" x 2" CEILING TUBE

1. Note overall layout of ceiling.
2. Identify location(s) of 2" x 2" horizontal ceiling tube(s) (A).
3. Using two self drilling screws, center and attach one 3/16" x 1-3/4" x 3" ceiling bracket (B) on posts(D) where horizontal ceiling tubes are to be installed.
  - a. Place so that leg of ceiling bracket is flush with top leg of wall panel per Fig. 1.
  - b. Clamp part in place before using self drilling screws.
4. Align horizontal ceiling tube (A) with posts (D), attach to bracket (B) with self-drilling screws per Fig. 2.
  - a. See detail page 23 if one end of ceiling tube mounts directly to building wall.
5. Install slotted angle (C) on top of wall panels per instruction page 19.
6. Lift panels into place, face side up, and attach to slotted angle with 3/8" x 1" bolts.
7. Use self drilling screws to attach panels to horizontal ceiling tubes Fig. 3.
  - a. Position panels to eliminate any sag in ceiling before fastening in place.

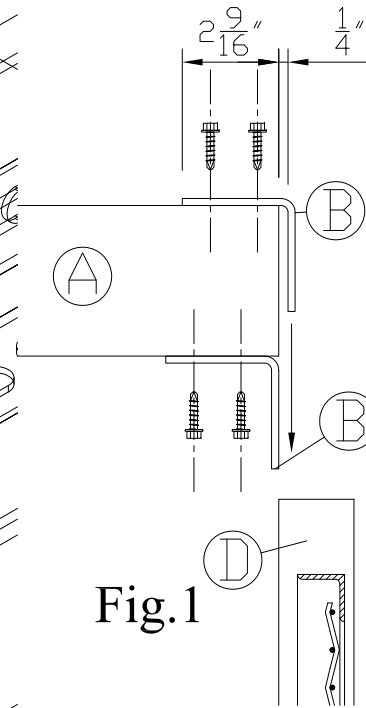
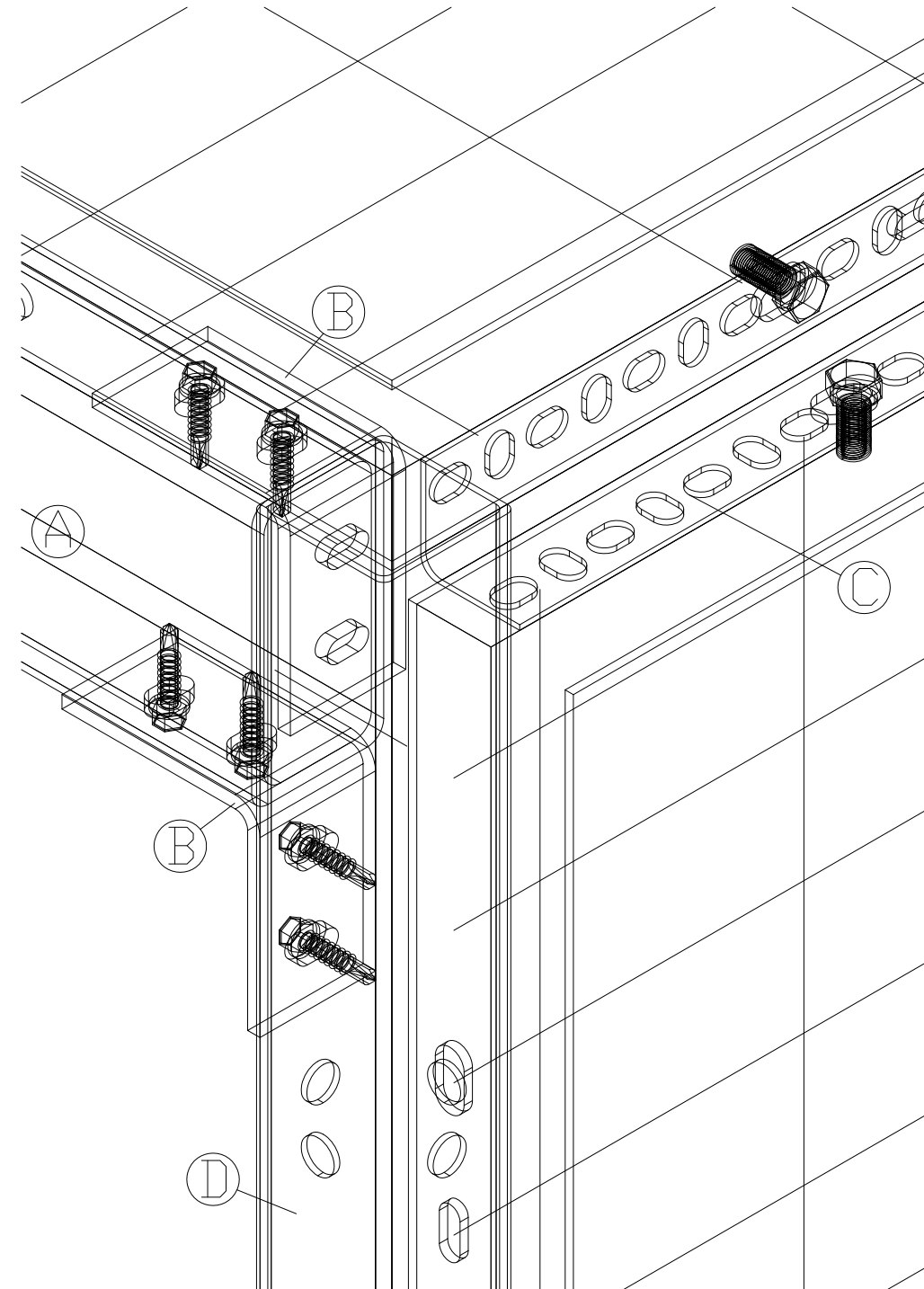

Fig.1

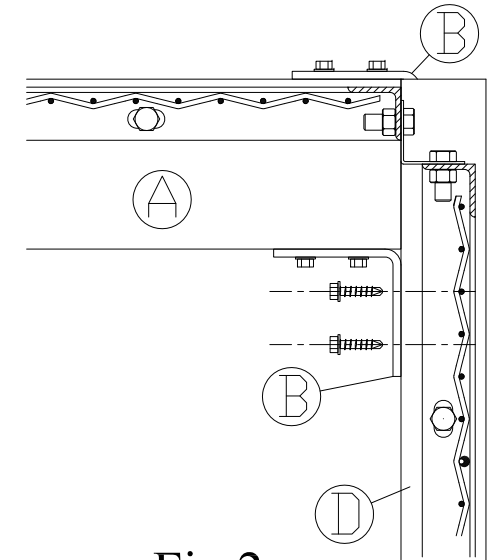
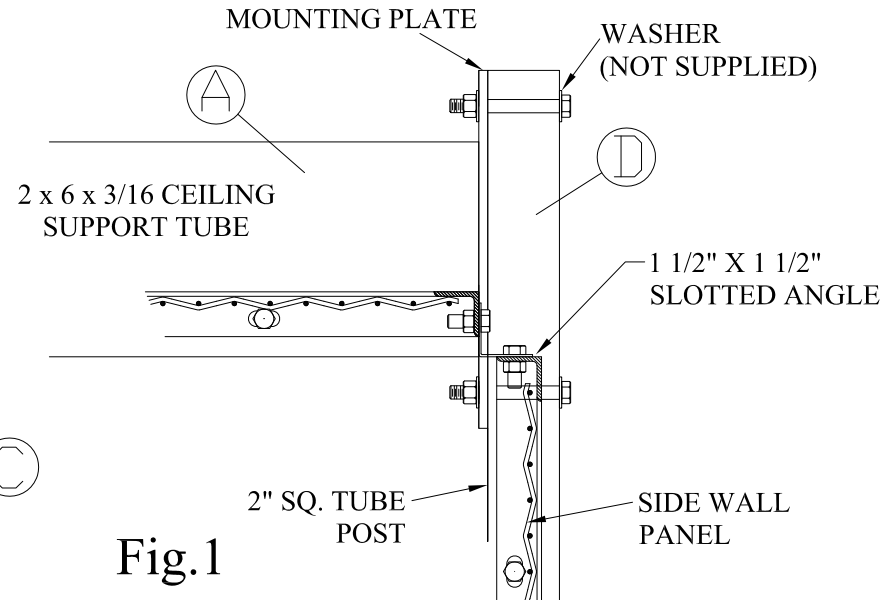
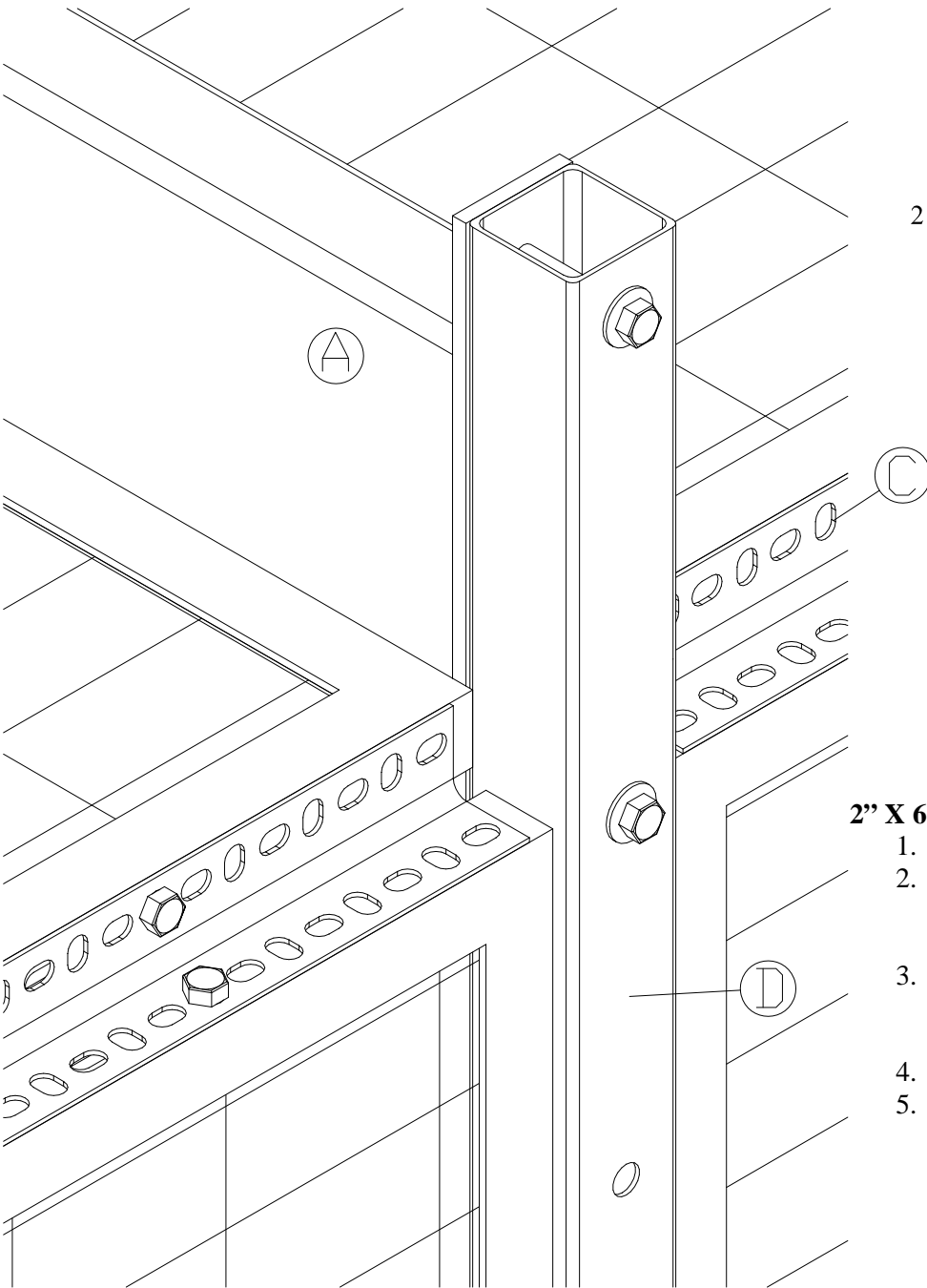

Fig.2

### 2" X 4" CEILING TUBE

1. Note location(s) of 2" x 4" horizontal ceiling tube(s) (A).
2. Center and attach one 3/16" x 1-3/4" x 3" Angle Bracket (B) to the top 2" side of 2" x 4" Ceiling Tube with two self-drill screws so that bracket leg hangs over the tube's open end.
  - a. Leave 1/4" gap between tube end and bracket leg per Fig 1.
3. Center and attach a second 3/16" x 1-3/4" x 3" Angle Bracket (B) to the bottom side of the 2" x 4" ceiling tube so that the bracket leg is flush with the end of the tube.
  - a. Both bracket legs should be pointing in the same direction. See Fig 1.
4. If opposite end of tube attaches to a post, repeat steps 2 & 3 for the opposite end of tube.
  - a. See detail page 23 if one end of ceiling tube mounts directly to building wall.
5. Lift ceiling tube (A) above the partition wall post (D) and lower into place so that the top bracket fits inside of wall post (D) Per Fig 2.
6. Align ceiling tube(A) with wall post(D) and secure lower bracket to post using self drilling screws see Fig.2
7. Install slotted angle on top of wall panels per instruction page 19.
8. Lift panels into place, face side up, and attach to slotted angle (C) with 3/8" x 1" bolts (see Fig.3 page 20).
9. Attach panels to ceiling Tube using 3/8" x 3" bolts.
  - a. Position panels to eliminate any sag in ceiling before fastening in place.



### 2" X 6" CEILING TUBE

1. Note location(s) of 2" x 6" horizontal ceiling tube(s) (A).
2. Lift ceiling tube (A) so that holes in mounting plates match holes at top of partition wall post (D).
  - a. See detail page 23 if one end of ceiling tube mounts directly to building wall.
3. Connect ceiling tube to wall post with two 3/8" x 3" bolts and nuts, and tighten securely.
  - a. Installer: use 3/8" flat washer (not provided) on nut and bolt side see Fig.1
4. Install slotted angle (C) on top of wall panels per instruction page 19.
5. Use 3/8" x 3" bolts to attach ceiling panels to 2" x 6" ceiling tube.

**2" X 4" TUBE CONNECTION  
TO MASONRY WALL**

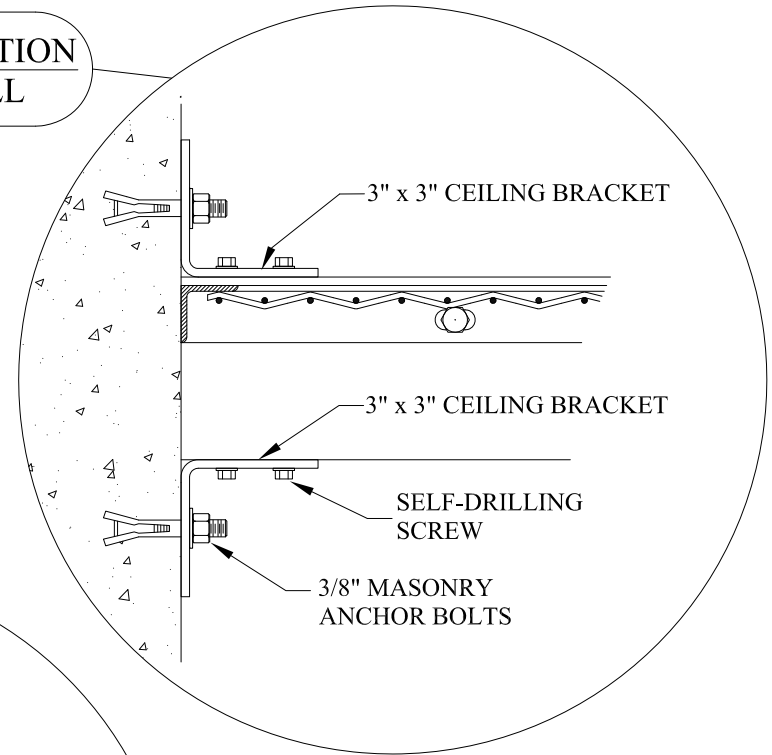
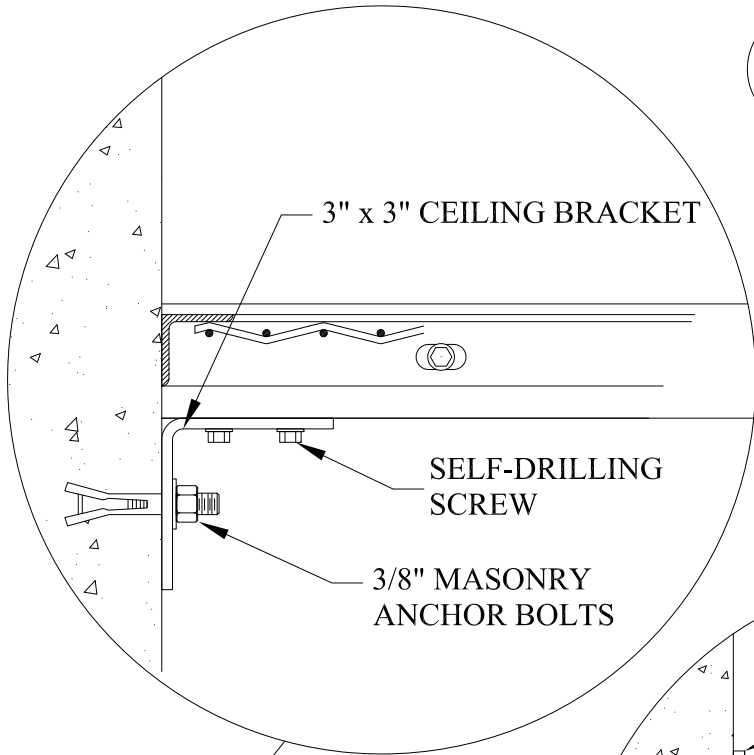

**2" X 2" TUBE CONNECTION  
TO MASONRY WALL**

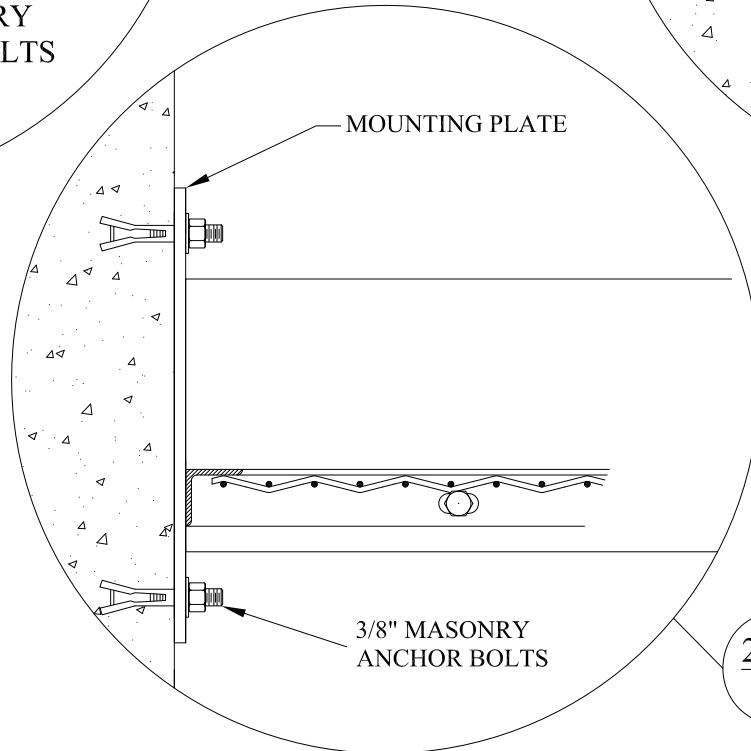

**2" X 6" TUBE CONNECTION  
TO MASONRY WALL**